

@P|•@æš@æ@æ)ã^iÁK

Sè|cÈÖ:|jã
ÖÈ AU-æ|ãã^iÁF
FGÈJÁÖ:|jã
Q)KÈI JÁHEÁI ÁFEÁ ÈÁGG
QæKÈI JÁHEÁI ÁFEÁ ÈÁCF
TæãKÈI JÁHEÁI ÁFEÁ ÈÁÈÁ
Qc|}^dã, Èæ|cÈã^iÁjã Èx{



HOSHIZAKI SELF-CONTAINED CUBER

MODEL **IM-45CLE
IM-45CLE-25**

PARTS LIST

[HE , GENERAL (50Hz) , EXPORT (60Hz) , AUSTRALIA , OCEANIA , HSP , KOREA , CHINA]

| | | | | | |
|-----|-----------|-----|-----------|-----|-----------|
| H-1 | MAY. 1998 | E-0 | DEC. 2004 | V-0 | JAN. 2010 |
| J-0 | DEC. 1998 | E-1 | APR. 2005 | L-0 | JAN. 2011 |
| K-0 | DEC. 1999 | E-2 | NOV. 2005 | | |
| K-1 | FEB. 2000 | F-0 | DEC. 2005 | | |
| A-0 | DEC. 2000 | G-0 | JAN. 2007 | | |
| B-0 | DEC. 2001 | G-1 | JUN. 2007 | | |
| B-1 | JUN. 2002 | G-2 | DEC. 2007 | | |
| C-0 | DEC. 2002 | T-0 | JAN. 2008 | | |
| D-0 | DEC. 2003 | T-1 | AUG. 2008 | | |
| D-1 | NOV. 2004 | U-0 | JAN. 2009 | | |

MATERIAL ABBREVIATIONS

ALUMINUM

AL = Aluminum

COPPER

CU = Copper

PLASTIC

ABS = Acrylonitrile -butadiene - styrene
AC = Polyacetal
EVA = Ethylene vinyl acetate
PA = Polyamide = Nylon
PC = Polycarbonate
PE = Polyethylene
PES = Polyester
PETP = Polyethylene terephthalate = Tetlon
PP = Polypropylene
PS = Polystyrene
PTFE = Polytetrafluoroethylene = Teflon
PUR = Polyurethane
PVC = Polyvinyl chloride

RUBBER

VN = Vinyl Nitrile
EPDM = EP rubber
NBR = Nitrile butadiene rubber
NR = Natural rubber
NP = Neoprene
SI.R = Silicone rubber
SY.R = Synthetic rubber
EPH = Epichlorohydrin

STEEL

GS = Galvanized steel
SS = Stainless steel
PS = Plated steel
PAS = Primed steel

AUXILIARY CODE

K-0

Designates the year. "K" indicates the year 2000. Years progress or regress in alphabetical order. "J" is 1999, "L" is 2001, "M" is 2002, and so on. The letters "I" and "O" were skipped.
Designates significant part changes within the same year. Base is 0 and this number advances for each change.

Example: P-1

"P" indicates 2004.

"1" indicates the first significant part change for 2004.

MARKS LOCATED UNDER THE AUXILIARY CODE

- = Part deleted.
- x = Part deleted and replaced by "o" part.
- o = New part in place of "x" part.

FASTENER ABBREVIATION LIST

| | | |
|-----|---|---|
| ST | = | Phillips Truss Head Machine Screw |
| SP | = | Phillips Pan Head Machine Screw |
| SF | = | Phillips Flat Head Machine Screw |
| SS | = | Phillips Pan Head Machine Screw with Split Lock Washer |
| SW | = | Phillips Pan Head Machine Screw with Split Lock Washer and Flat Washer |
| T1 | = | Phillips Truss Head Tapping Screw (Correspond to Type A) |
| T2 | = | Phillips Truss Head Tapping Screw (Correspond to Type B) |
| T3 | = | Phillips Truss Head Tapping Screw (Correspond to Type C) |
| FT | = | Phillips Truss Head Tapping Screw (Special) |
| BH | = | Hexagon Head Bolt |
| BC | = | Socket Head Cap Screw |
| BS | = | Hexagon Bolt with Split Washer |
| BW | = | Hexagon Bolt with Split Washer and Flat Washer |
| BF | = | Hexagon Flange Bolt |
| BR | = | Cross-Recessed Hexagon Head Bolt |
| BRW | = | Cross-Recessed Hexagon Head Bolt with Split Lock Washer and Flat Washer |
| WL | = | Split Lock Washer |
| WT | = | External Tooth Washer |
| WF | = | Flat Washer |
| WS | = | Spring Washer |
| NH | = | Hexagon Nut |
| NF | = | Hexagon Flange Nut |
| NC | = | Hexagon Cap Nut |
| NS | = | Square Nut |
| NW | = | Wing Nut |

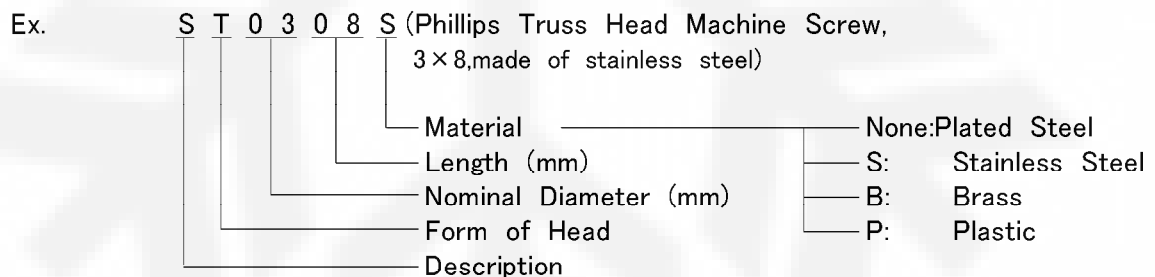

(Note) Second character is numerical except the list.
 Ex: S1,S2,B3 etc.

And abbreviations and names are shown under the illustration.

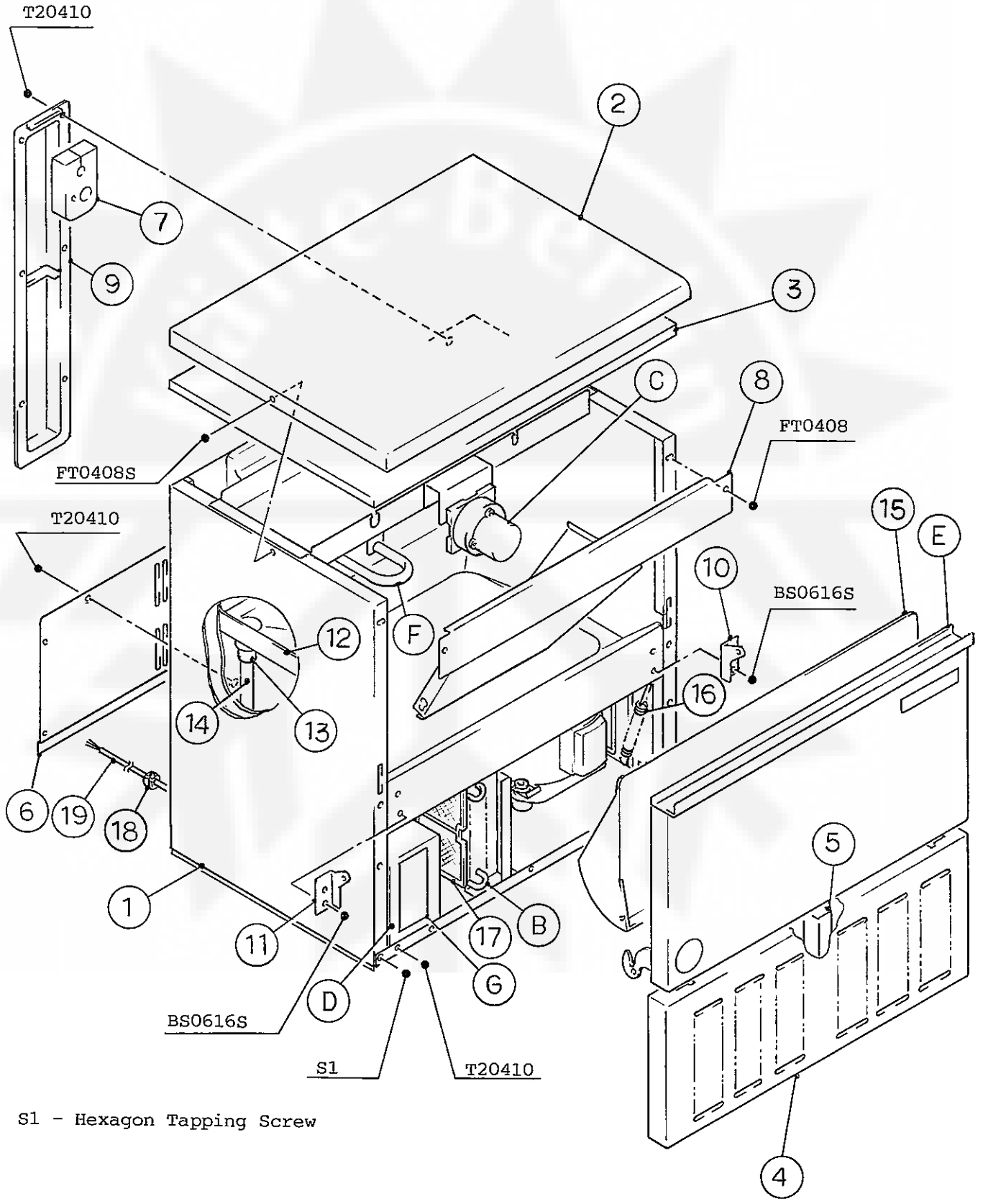

S1 - Hexagon Tapping Screw

IM-45CLE-25
IM-45CLE

A. ICE CUBER ASSY

(E-2) to (T-0)
(D-0) (D-1) (E-0) (E-1)
(A-0) (B-0) (B-1) (C-0)
(H-1) (J-0) (K-0) (K-1)

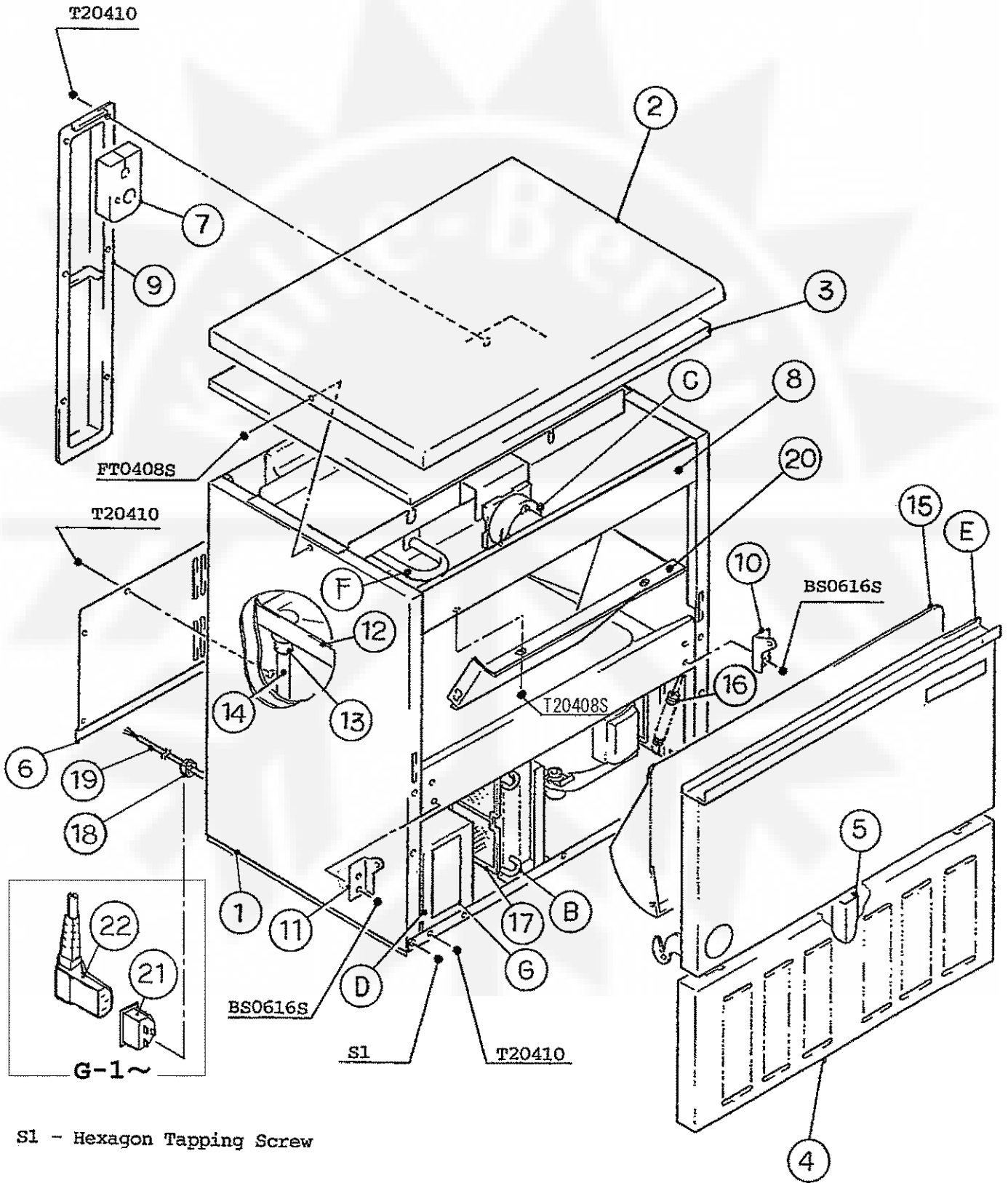

S1 - Hexagon Tapping Screw

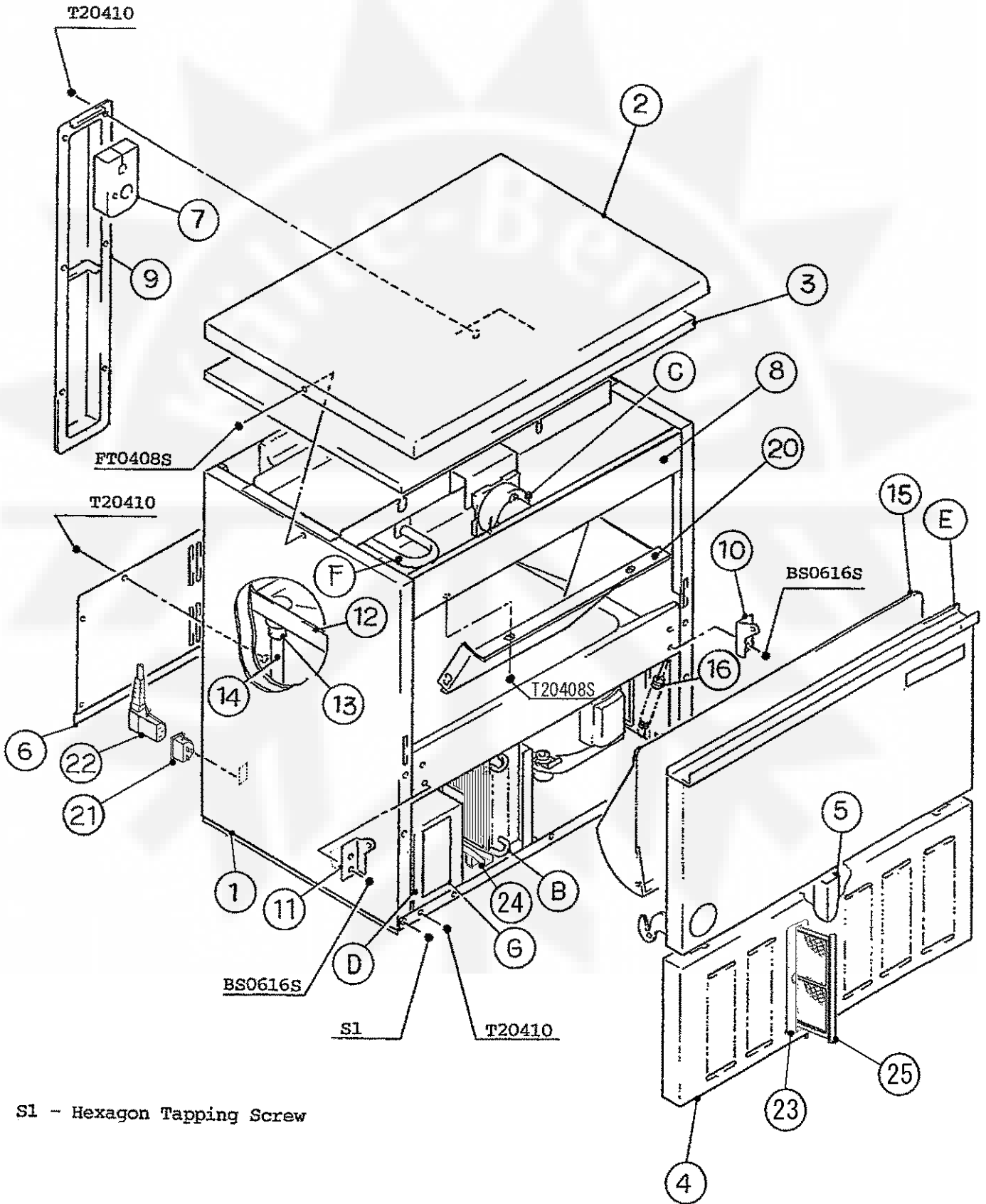

S1 - Hexagon Tapping Screw

HE, GENERAL(50Hz), EXPORT(60Hz), AUSTRALIA, OCEANIA, HSP,KOREA

| MODEL : IM-45CLE-25, IM-45CLE | | | | TITLE : A. ICE CUBER ASSY | | | |
|-------------------------------|---------------------------|--------------------------|-------------|---------------------------|-------------------|-------------------|------------|
| INDEX NO. | DESCRIPTION | MATERIAL OR MODEL NUMBER | PART NUMBER | REQ'D NUMBER | | | |
| | | | | H-1 J-0 K-0 | K-1 A-0 B-0 | B-1 C-0 D-0 | D-1 E-0 |
| B | REFRIGERATION UNIT | (IM-45CLE-25) | 1H1769A01 | 1 | 1 | 1 | 1 |
| | | | 1H3339A01 | | | | |
| | REFRIGERATION UNIT | (IM-45CLE) | - | 1 | 1 | 1 | 1 |
| C | ICE MAKING MECHANISM ASSY | (IM-45CLE-25) | 1H1770A01 | 1 | - | | |
| | | | 1H1770A02 | | 1 | 1 | 1 |
| | ICE MAKING MECHANISM ASSY | (IM-45CLE) | - | 1 | 1 | 1 | 1 |
| D | CONTROL BOX ASSY | - | 2H3637A01 | 1 | - | | |
| | | - | 2H3637A02 | | 1 | 1 | - |
| | | - | 2H3637A03 | | | | 1 |
| | | - | 2H6751A01 | | | | |
| E | DOOR ASSY | - | 3X1614A01 | 1 | 1 | 1 | 1 |
| | | - | 3Y2781A01 | | | | |
| | | - | 3Y2905A01 | | | | |
| F | WATER CIRCUIT | - | 3H9600A02 | 1 | 1 | 1 | 1 |
| G | LABEL LOCATION | - | 3X1619A01 | 1 | 1 | 1 | 1 |
| | | - | 3X1619A02 | | | | |
| 1 | UNIT FRAME | S.S, G.S | 1H1760G01 | 1 | 1 | - | |
| | | S.S, G.S | 1H1760G02 | | | 1 | 1 |
| | | S.S, G.S | 1H1760G03 | | | | |
| 2 | TOP PANEL | S.S | 3H9606-03 | 1 | 1 | 1 | 1 |
| 3 | INSULATION - TOP PANEL | PE | 3X1613G01 | 1 | 1 | 1 | 1 |
| 4 | FRONT PANEL | S.S | 3X1615-01 | 1 | 1 | 1 | 1 |
| 5 | SEAL (A) | PE | 4H4359-01 | 1 | 1 | 1 | 1 |
| 6 | REAR PANEL | G.S | 3X1616-01 | 1 | 1 | 1 | 1 |
| 7 | INSULATION | PE | 4X5295-01 | 1 | 1 | 1 | 1 |
| 8 | FRONT FRAME | S.S | 3X1617G01 | 1 | 1 | - | |
| | | S.S | 3X6086-02 | | | 1 | 1 |
| 9 | PIPE COVER | G.S | 3H0172-02 | 1 | 1 | 1 | 1 |
| 10 | HINGE (RIGHT) | S.S | 4H2583-01 | 1 | 1 | 1 | 1 |
| 11 | HINGE (LEFT) | S.S | 4H2584-01 | 1 | 1 | 1 | 1 |
| 12 | DRAIN PAN | ABS | 2H1440-01 | 1 | 1 | 1 | 1 |
| 13 | DRAIN TUBE | SI | 4H2585-01 | 1 | 1 | 1 | 1 |
| 14 | DRAIN PIPE | ABS | 4H1141-12 | 1 | 1 | 1 | 1 |
| 15 | SLOPE | ABS | 2H1349-02 | 1 | 1 | 1 | 1 |

HE, GENERAL(50Hz), EXPORT(60Hz), AUSTRALIA, OCEANIA, HSP,KOREA

| MODEL : IM-45CLE-25, IM-45CLE | | | | TITLE : A. ICE CUBER ASSY | | | | |
|-------------------------------|---------------------------|--------------------------|-------------|---------------------------|-------------------|-----|------------|--|
| INDEX NO. | DESCRIPTION | MATERIAL OR MODEL NUMBER | PART NUMBER | REQ'D NUMBER | | | | |
| | | | | E-1 | E-2 F-0 G-0 | G-1 | G-2 T-0 | |
| B | REFRIGERATION UNIT | (IM-45CLE-25) | 1H1769A01 | 1 | | | | |
| | | | 1H3339A01 | | 1 | 1 | 1 | |
| | REFRIGERATION UNIT | (IM-45CLE) | - | 1 | 1 | 1 | 1 | |
| C | ICE MAKING MECHANISM ASSY | (IM-45CLE-25) | - | | | | | |
| | | | 1H1770A02 | 1 | 1 | 1 | 1 | |
| | ICE MAKING MECHANISM ASSY | (IM-45CLE) | - | 1 | 1 | 1 | 1 | |
| D | CONTROL BOX ASSY | - | - | | | | | |
| | | - | - | | | | | |
| | | | 2H3637A03 | - | | | | |
| | | | 2H6751A01 | 1 | 1 | 1 | 1 | |
| E | DOOR ASSY | - | 3X1614A01 | 1 | 1 | 1x | | |
| | | - | 3Y2781A01 | | | ○1 | - | |
| | | - | 3Y2905A01 | | | | 1 | |
| F | WATER CIRCUIT | - | 3H9600A02 | 1 | 1 | 1 | 1 | |
| G | LABEL LOCATION | - | 3X1619A01 | - | | | | |
| | | - | 3X1619A02 | 1 | 1 | 1 | 1 | |
| 1 | UNIT FRAME | - | - | | | | | |
| | | S.S, G.S | 1H1760G02 | 1 | 1 | - | | |
| | | S.S, G.S | 1H1760G03 | | | 1 | 1 | |
| 2 | TOP PANEL | S.S | 3H9606-03 | 1 | 1 | 1 | 1 | |
| 3 | INSULATION - TOP PANEL | PE | 3X1613G01 | 1 | 1 | 1 | 1 | |
| 4 | FRONT PANEL | S.S | 3X1615-01 | 1 | 1 | 1 | 1 | |
| 5 | SEAL (A) | PE | 4H4359-01 | 1 | 1 | 1 | 1 | |
| 6 | REAR PANEL | G.S | 3X1616-01 | 1 | 1 | 1 | 1 | |
| 7 | INSULATION | PE | 4X5295-01 | 1 | 1 | 1 | 1 | |
| 8 | FRONT FRAME | - | - | | | | | |
| | | S.S | 3X6086-02 | 1 | 1 | 1 | 1 | |
| 9 | PIPE COVER | G.S | 3H0172-02 | 1 | 1 | 1 | 1 | |
| 10 | HINGE (RIGHT) | S.S | 4H2583-01 | 1 | 1 | 1 | 1 | |
| 11 | HINGE (LEFT) | S.S | 4H2584-01 | 1 | 1 | 1 | 1 | |
| 12 | DRAIN PAN | ABS | 2H1440-01 | 1 | 1 | 1 | 1 | |
| 13 | DRAIN TUBE | SI | 4H2585-01 | 1 | 1 | 1 | 1 | |
| 14 | DRAIN PIPE | ABS | 4H1141-12 | 1 | 1 | 1 | 1 | |
| 15 | SLOPE | ABS | 2H1349-02 | 1 | 1 | 1 | 1 | |

HE, GENERAL(50Hz), EXPORT(60Hz), AUSTRALIA, OCEANIA, HSP,KOREA,CHINA

| MODEL : IM-45CLE-25, IM-45CLE | | | | | TITLE : A. ICE CUBER ASSY | | | |
|-------------------------------|---------------------------|--------------------------|-------------|--------------------|---------------------------|--|--|--|
| INDEX NO. | DESCRIPTION | MATERIAL OR MODEL NUMBER | PART NUMBER | REQ'D NUMBER | | | | |
| | | | | T-1,U-0 V-0,L-0 | | | | |
| B | REFRIGERATION UNIT | (IM-45CLE-25) | 1H3339A01 | — | | | | |
| | REFRIGERATION UNIT | (IM-45CLE) | 1H3339A02 | 1 | | | | |
| C | REFRIGERATION UNIT | (IM-45CLE) | - | 1 | | | | |
| | ICE MAKING MECHANISM ASSY | (IM-45CLE-25) | 1H1770A02 | 1 | | | | |
| D | ICE MAKING MECHANISM ASSY | (IM-45CLE) | - | 1 | | | | |
| | CONTROL BOX ASSY | | 2H6751A01 | 1 | | | | |
| E | DOOR ASSY | - | 3Y2905A01 | 1 | | | | |
| F | WATER CIRCUIT | - | 3H9600A02 | 1 | | | | |
| G | LABEL LOCATION | - | 3X1619A02 | 1 | | | | |
| 1 | UNIT FRAME | S.S, G.S | 1H1760G03 | 1 | | | | |
| 2 | TOP PANEL | S.S | 3H9606-03 | 1 | | | | |
| 3 | INSULATION - TOP PANEL | PE | 3X1613G01 | 1 | | | | |
| 4 | FRONT PANEL | S.S | 3X1615-01 | — | | | | |
| | FRONT PANEL | S.S | 3Y3675G01 | 1 | | | | |
| 5 | SEAL (A) | PE | 4H4359-01 | 1 | | | | |
| 6 | REAR PANEL | G.S | 3X1616-01 | 1 | | | | |
| 7 | INSULATION | PE | 4X5295-01 | 1 | | | | |
| 8 | FRONT FRAME | S.S | 3X6086-02 | 1 | | | | |
| 9 | PIPE COVER | G.S | 3H0172-02 | 1 | | | | |
| 10 | HINGE (RIGHT) | S.S | 4H2583-01 | 1 | | | | |
| 11 | HINGE (LEFT) | S.S | 4H2584-01 | 1 | | | | |
| 12 | DRAIN PAN | ABS | 2H1440-01 | 1 | | | | |
| 13 | DRAIN TUBE | SI | 4H2585-01 | 1 | | | | |
| 14 | DRAIN PIPE | ABS | 4H1141-12 | 1 | | | | |
| 15 | SLOPE | ABS | 2H1349-02 | 1 | | | | |
| 16 | SPRING | ZINC-PLATED WIRE | 4X5639-01 | 1 | | | | |
| 17 | AIR FILTER | PP | 208284G01 | × | | | | |
| 18 | - | - | - | | | | | |
| 19 | - | - | - | | | | | |
| 20 | FRONTO FRAME(LO) | S.S | 2H4624-01 | 1 | | | | |
| 21 | CONNECTOR | - | P00245-01 | 1 | | | | |

HE, GENERAL(50Hz), EXPORT(60Hz), AUSTRALIA, OCEANIA, HSP, KOREA

| MODEL : IM-45CLE-25, IM-45CLE | | | | TITLE : A. ICE CUBER ASSY | | | |
|-------------------------------|-------------------------------------|-----------------------------------|-------------|---------------------------|-------------------|-------------------|------------|
| INDEX NO. | DESCRIPTION | MATERIAL OR MODEL NUMBER | PART NUMBER | REQ'D NUMBER | | | |
| | | | | H-1 J-0 K-0 | K-1 A-0 B-0 | B-1 C-0 D-0 | D-1 E-0 |
| 16 | SPRING | ZINC-PLATED WIRE | 4X5639-01 | 1 | 1 | 1 | 1 |
| 17 | AIR FILTER | PP | 208284G01 | 1 | 1 | 1 | 1 |
| 18 | BUSHING | CEE SR-6P-10 | 448949-01 | 1 | 1 | 1 | 1 |
| 19 | POWER SUPPLY CORD (CONTINENTAL) | (HE) (KOREA) (EXPORT) | 452263-01 | 1 | 1 | 1 | 1 |
| | POWER SUPPLY CORD (WITH UK PLUG) | (HE) (GENERAL) | 4X3521G01 | 1 | 1 | 1 | 1 |
| | POWER SUPPLY CORD | (AUSTRALIA) (OCEANIA) (HSP) | 458139-01 | 1 | 1 | 1 | 1 |
| 20 | FRONT FRAME(LO) | S.S | 2H4624-01 | | | 1 | 1 |
| | | | | | | | |
| | | | | | | | |
| | | | | | | | |
| | | | | | | | |
| | | | | | | | |
| | | | | | | | |
| | | | | | | | |
| | | | | | | | |
| | | | | | | | |
| | | | | | | | |
| | | | | | | | |
| | | | | | | | |
| | | | | | | | |
| | | | | | | | |
| | | | | | | | |
| | | | | | | | |
| | | | | | | | |
| | | | | | | | |

HE, GENERAL(50Hz), EXPORT(60Hz), AUSTRALIA, OCEANIA, HSP,KOREA

| MODEL : IM-45CLE-25, IM-45CLE | | | | TITLE : A. ICE CUBER ASSY | | | |
|-------------------------------|-------------------------------------|-----------------------------------|-------------|---------------------------|-------------------|-----|------------|
| INDEX NO. | DESCRIPTION | MATERIAL OR MODEL NUMBER | PART NUMBER | REQ'D NUMBER | | | |
| | | | | E-1 | E-2 F-0 G-0 | G-1 | G-2 T-0 |
| 16 | SPRING | ZINC-PLATED WIRE | 4X5639-01 | 1 | 1 | 1 | 1 |
| 17 | AIR FILTER | PP | 208284G01 | 1 | 1 | 1 | 1 |
| 18 | BUSHING | CEE SR-6P-10 | 448949-01 | 1 | 1 | x | |
| 19 | POWER SUPPLY CORD (CONTINENTAL) | (HE) (KOREA) (EXPORT) | 452263-01 | 1 | 1 | x | |
| | POWER SUPPLY CORD (WITH UK PLUG) | (HE) (GENERAL) | 4X3521G01 | 1 | 1 | x | |
| | POWER SUPPLY CORD | (AUSTRALIA) (OCEANIA) (HSP) | 458139-01 | 1 | 1 | x | |
| 20 | FRONTO FRAME(LO) | S.S | 2H4624-01 | 1 | 1 | 1 | 1 |
| 21 | CONNECTOR | - | P00245-01 | | | 1 | 1 |
| 22 | POWER CORD | (CONTINENTAL) | P00240-01 | | | 1 | 1 |
| | POWER CORD (WITH UK PLUG) | (UK) | P00241-01 | | | 1 | 1 |
| | POWER CORD | (AUSTRALIA) | P00242-01 | | | 1 | 1 |
| | | | | | | | |
| | | | | | | | |
| | | | | | | | |
| | | | | | | | |
| | | | | | | | |
| | | | | | | | |
| | | | | | | | |
| | | | | | | | |
| | | | | | | | |
| | | | | | | | |
| | | | | | | | |
| | | | | | | | |
| | | | | | | | |
| | | | | | | | |

IM-45CLE-25
IM-45CLE

B. REFRIGERATION UNIT

(D-0) (D-1) (E-0) (E-1) and later
(A-0) (B-0) (B-1) (C-0)
(H-1) (J-0) (K-0) (K-1)

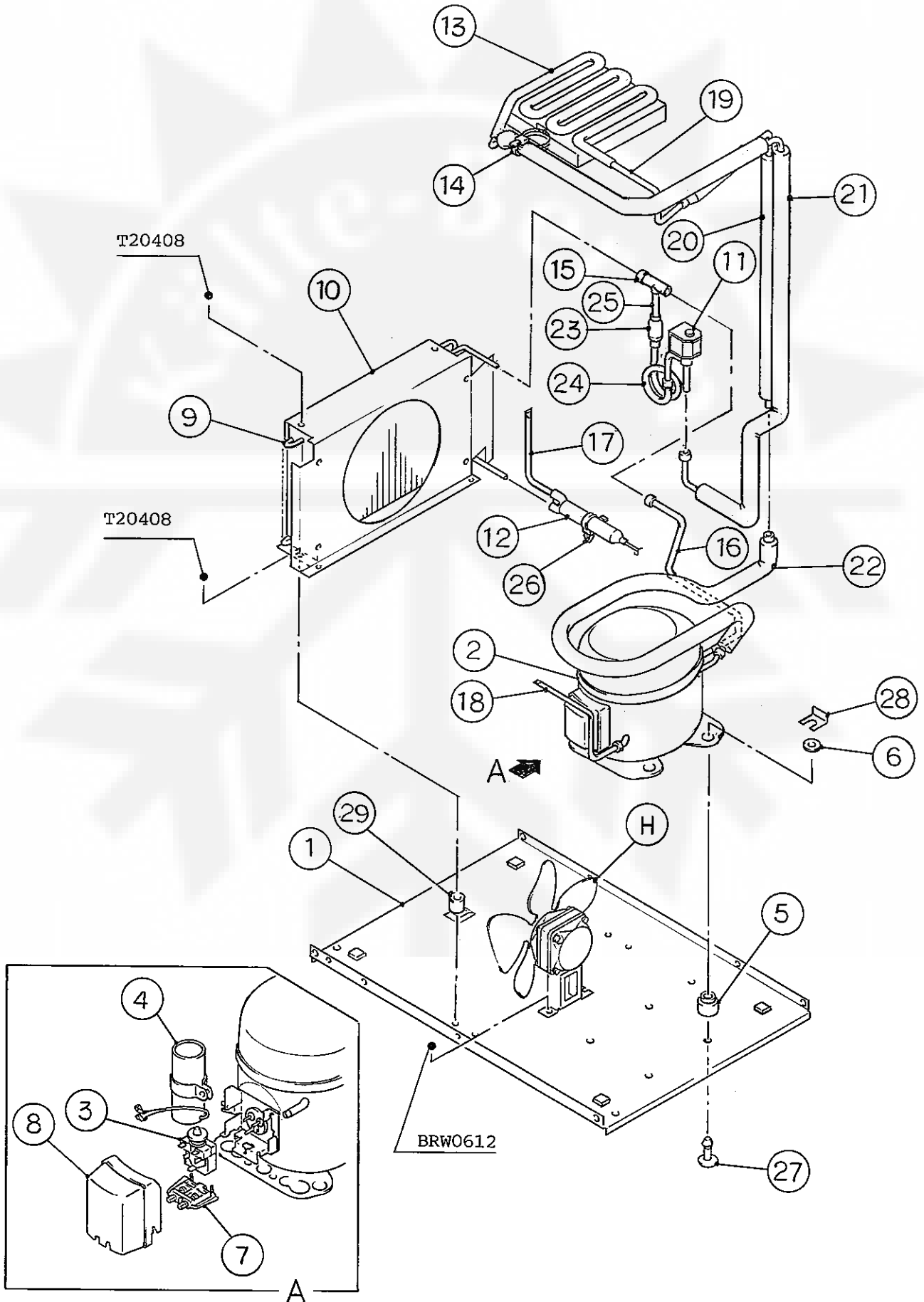

HE, GENERAL(50Hz), EXPORT(60Hz), AUSTRALIA, OCEANIA, HSP,KOREA

| MODEL : IM-45CLE-25, IM-45CLE | | | | TITLE : B:REFRIGERATION UNIT | | | |
|-------------------------------|---------------------------|--------------------------|-------------|------------------------------|-------------------|-------------------|------------|
| INDEX NO. | DESCRIPTION | MATERIAL OR MODEL NUMBER | PART NUMBER | REQ'D NUMBER | | | |
| | | | | H-1 J-0 K-0 | K-1 A-0 B-0 | B-1 C-0 D-0 | D-1 E-0 |
| H | FAN MOTOR ASSY | (S-9023) | 3X1631A01 | 1 | 1 | 1 | 1 |
| 1 | BASE | G.S | 2H3662G01 | 1 | 1 | 1 | 1 |
| 2 | COMPRESSOR | FR8.5G | 450891-01 | 1 | 1 | 1 | 1 |
| 3 | STARTING RELAY | 117U6015 | 450893-01 | 1 | 1 | 1 | 1 |
| 4 | STARTING CAPACITOR | 117U5015 | 450898-01 | 1 | 1 | 1 | 1 |
| 5 | RUBBER GROMMET | - | 450897-01 | 4 | 4 | 4 | 4 |
| 6 | WASHER | - | 450894-01 | 4 | 4 | 4 | 4 |
| 7 | CORD RELIEF | 103N1006 | 450899-01 | 1 | 1 | 1 | 1 |
| 8 | COVER | 103N201 | 450896-01 | 1 | 1 | 1 | 1 |
| 9 | CONDENSER - AIR-COOLED | - | 2H3635-01 | 1 | 1 | 1 | 1 |
| 10 | SHROUD | G.S | 2H3670-01 | 1 | 1 | 1 | 1 |
| 11 | HOT GAS SOLENOID VALVE | AMS-24B10HD-1 | 418866-02 | 1 | 1 | 1 | 1 |
| 12 | DRIER | DY-15QHD-10 | 458773-01 | 1 | 1 | 1 | 1 |
| | | DY-12QHD-3 | 445655-04 | | | | |
| 13 | EVAPORATOR | (IM-45CLE-25) | 3H3941G01 | 1 | 1 | 1 | 1 |
| | EVAPORATOR | (IM-45CLE) | 3H8105G01 | 1 | 1 | 1 | 1 |
| 14 | TIE | CV-100 | 7920-0002 | REQ'D | REQ'D | REQ'D | REQ'D |
| 15 | TEE | COPPER | 420041-03 | 1 | 1 | 1 | 1 |
| 16 | COPPER TUBE (H) | COPPER | 3X1627-01 | 1 | 1 | 1 | 1 |
| 17 | PROCESS TUBE (A) | COPPER | 4H4698-01 | 1 | 1 | 1 | 1 |
| 18 | PROCESS TUBE (B) | COPPER | 4X3379-01 | 1 | 1 | 1 | 1 |
| 19 | HEAT EXCHANGER | COPPER | 4X5640G01 | 1 | 1 | 1 | 1 |
| 20 | INSULATION TUBE (A) | 13 ID x 23 OD, L=360 | 7762-1323 | 1 | 1 | 1 | 1 |
| 21 | COPPER TUBE (B) - HOT GAS | COPPER | 3X1630G01 | 1 | 1 | 1 | 1 |
| 22 | COPPER TUBE (L) | COPPER | 3X2156G01 | 1 | 1 | 1 | 1 |
| 23 | STRAINER | COPPER | 451772-01 | 1 | 1 | 1 | 1 |
| 24 | COPPER TUBE (A) - HOT GAS | COPPER | 4H7545-01 | 1 | 1 | 1 | 1 |
| 25 | COPPER TUBE (C) - HOT GAS | COPPER | 4H7544-01 | 1 | 1 | 1 | 1 |
| 26 | TIE | RT30SSF5 | 457167-01 | 1 | 1 | 1 | 1 |
| 27 | STEEL PIN | | 452255-01 | 4 | 4 | 4 | 4 |
| 28 | CLIP | | 452256-01 | 4 | 4 | 4 | 4 |
| 29 | TUBE - SILICONE | SI. R, 6 ID x t1.0 | 4X6549-01 | 1 | 1 | 1 | 1 |
| | | | | | | | |

HE, GENERAL(50Hz), EXPORT(60Hz), AUSTRALIA, OCEANIA, HSP,KOREA

| MODEL : IM-45CLE-25, IM-45CLE | | | | TITLE : B:REFRIGERATION UNIT | | | |
|-------------------------------|---------------------------|--------------------------|-------------|------------------------------|-------------------|-------|------------|
| INDEX NO. | DESCRIPTION | MATERIAL OR MODEL NUMBER | PART NUMBER | REQ'D NUMBER | | | |
| | | | | E-1 | E-2 F-0 G-0 | G-1 | G-2 T-0 |
| H | FAN MOTOR ASSY | (S-9023) | 3X1631A01 | 1 | 1 | 1 | 1 |
| 1 | BASE | G.S | 2H3662G01 | 1 | 1 | 1 | 1 |
| 2 | COMPRESSOR | FR8.5G | 450891-01 | 1 | 1 | 1 | 1 |
| 3 | STARTING RELAY | 117U6015 | 450893-01 | 1 | 1 | 1 | 1 |
| 4 | STARTING CAPACITOR | 117U5015 | 450898-01 | 1 | 1 | 1 | 1 |
| 5 | RUBBER GROMMET | - | 450897-01 | 4 | 4 | 4 | 4 |
| 6 | WASHER | - | 450894-01 | 4 | 4 | 4 | 4 |
| 7 | CORD RELIEF | 103N1006 | 450899-01 | 1 | 1 | 1 | 1 |
| 8 | COVER | 103N201 | 450896-01 | 1 | 1 | 1 | 1 |
| 9 | CONDENSER - AIR-COOLED | - | 2H3635-01 | 1 | 1 | 1 | 1 |
| 10 | SHROUD | G.S | 2H3670-01 | 1 | 1 | 1 | 1 |
| 11 | HOT GAS SOLENOID VALVE | AMS-24B10HD-1 | 418866-02 | 1 | 1 | 1 | 1 |
| 12 | DRIER | DY-15QHD-10 | 458773-01 | 1 | — | | |
| | | DY-12QHD-3 | 445655-04 | | 1 | 1 | 1 |
| 13 | EVAPORATOR | (IM-45CLE-25) | 3H3941G01 | 1 | 1 | 1 | 1 |
| | EVAPORATOR | (IM-45CLE) | 3H8105G01 | 1 | 1 | 1 | 1 |
| 14 | TIE | CV-100 | 7920-0002 | REQ'D | REQ'D | REQ'D | REQ'D |
| 15 | TEE | COPPER | 420041-03 | 1 | 1 | 1 | 1 |
| 16 | COPPER TUBE (H) | COPPER | 3X1627-01 | 1 | 1 | 1 | 1 |
| 17 | PROCESS TUBE (A) | COPPER | 4H4698-01 | 1 | 1 | 1 | 1 |
| 18 | PROCESS TUBE (B) | COPPER | 4X3379-01 | 1 | 1 | 1 | 1 |
| 19 | HEAT EXCHANGER | COPPER | 4X5640G01 | 1 | 1 | 1 | 1 |
| 20 | INSULATION TUBE (A) | 13 ID x 23 OD, L=360 | 7762-1323 | 1 | 1 | 1 | 1 |
| 21 | COPPER TUBE (B) - HOT GAS | COPPER | 3X1630G01 | 1 | 1 | 1 | 1 |
| 22 | COPPER TUBE (L) | COPPER | 3X2156G01 | 1 | 1 | 1 | 1 |
| 23 | STRAINER | COPPER | 451772-01 | 1 | 1 | 1 | 1 |
| 24 | COPPER TUBE (A) - HOT GAS | COPPER | 4H7545-01 | 1 | 1 | 1 | 1 |
| 25 | COPPER TUBE (C) - HOT GAS | COPPER | 4H7544-01 | 1 | 1 | 1 | 1 |
| 26 | TIE | RT30SSF5 | 457167-01 | 1 | 1 | 1 | 1 |
| 27 | STEEL PIN | | 452255-01 | 4 | 4 | 4 | 4 |
| 28 | CLIP | | 452256-01 | 4 | 4 | 4 | 4 |
| 29 | TUBE - SILICONE | SI. R, 6 ID x t1.0 | 4X6549-01 | 1 | 1 | 1 | 1 |
| | | | | | | | |

HE, GENERAL(50Hz), EXPORT(60Hz), AUSTRALIA, OCEANIA, HSP,KOREA,CHINA

| MODEL : IM-45CLE-25, IM-45CLE | | | | TITLE : B:REFRIGERATION UNIT | | | |
|-------------------------------|---------------------------|--------------------------|-------------|------------------------------|--|--|--|
| INDEX NO. | DESCRIPTION | MATERIAL OR MODEL NUMBER | PART NUMBER | REQ'D NUMBER | | | |
| | | | | T-1,U-0 V-0,L-0 | | | |
| H | FAN MOTOR ASSY | (S-9023) | 3X1631A01 | 1 | | | |
| 1 | BASE | G.S | 2H3662G01 | — | | | |
| | BASE | G.S | 2H9111G01 | 1 | | | |
| 2 | COMPRESSOR | FR8.5G | 450891-01 | 1 | | | |
| 3 | STARTING RELAY | 117U6015 | 450893-01 | 1 | | | |
| 4 | STARTING CAPACITOR | 117U5015 | 450898-01 | 1 | | | |
| 5 | RUBBER GROMMET | - | 450897-01 | 4 | | | |
| 6 | WASHER | - | 450894-01 | 4 | | | |
| 7 | CORD RELIEF | 103N1006 | 450899-01 | 1 | | | |
| 8 | COVER | 103N201 | 450896-01 | 1 | | | |
| 9 | CONDENSER - AIR-COOLED | - | 2H3635-01 | 1 | | | |
| 10 | SHROUD | G.S | 2H3670-01 | — | | | |
| | | | 2H9495M01 | 1 | | | |
| 11 | HOT GAS SOLENOID VALVE | AMS-24B10HD-1 | 418866-02 | 1 | | | |
| 12 | DRIER | DY-12QHD-3 | 445655-04 | 1 | | | |
| 13 | EVAPORATOR | (IM-45CLE-25) | 3H3941G01 | 1 | | | |
| | EVAPORATOR | (IM-45CLE) | 3H8105G01 | 1 | | | |
| 14 | TIE | CV-100 | 7920-0002 | REQ'D | | | |
| 15 | TEE | COPPER | 420041-03 | 1 | | | |
| 16 | COPPER TUBE (H) | COPPER | 3X1627-01 | 1 | | | |
| 17 | PROCESS TUBE (A) | COPPER | 4H4698-01 | 1 | | | |
| 18 | PROCESS TUBE (B) | COPPER | 4X3379-01 | 1 | | | |
| 19 | HEAT EXCHANGER | COPPER | 4X5640G01 | 1 | | | |
| 20 | INSULATION TUBE (A) | 13 ID x 23 OD, L=360 | 7762-1323 | 1 | | | |
| 21 | COPPER TUBE (B) - HOT GAS | COPPER | 3X1630G01 | 1 | | | |
| 22 | COPPER TUBE (L) | COPPER | 3X2156G01 | 1 | | | |
| 23 | STRAINER | COPPER | 451772-01 | 1 | | | |
| 24 | COPPER TUBE (A) - HOT GAS | COPPER | 4H7545-01 | 1 | | | |
| 25 | COPPER TUBE (C) - HOT GAS | COPPER | 4H7544-01 | 1 | | | |
| 26 | TIE | RT30SSF5 | 457167-01 | 1 | | | |
| 27 | STEEL PIN | | 452255-01 | 4 | | | |
| 28 | CLIP | | 452256-01 | 4 | | | |
| 29 | TUBE - SILICONE | SI. R, 6 ID x t1.0 | 4X6549-01 | 1 | | | |

IM-45CLE-25
IM-45CLE

C. ICE MAKING MECHANISM ASSY

(D-0) (D-1) (E-0) (E-1) and later
(A-0) (B-0) (B-1) (C-0)
(H-1) (J-0) (K-0) (K-1)

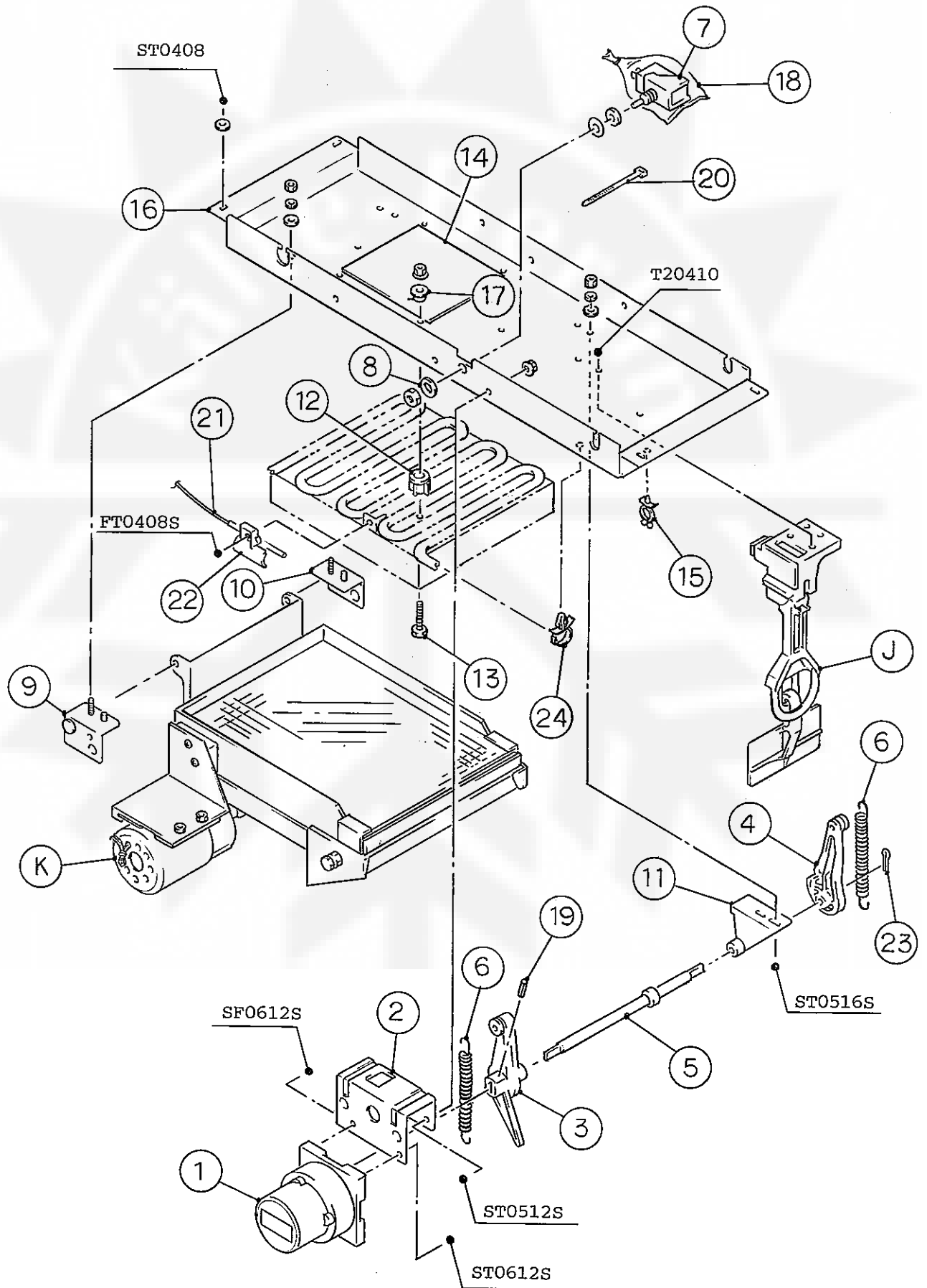

HE, GENERAL(50Hz), EXPORT(60Hz), AUSTRALIA, OCEANIA, HSP,KOREA

| MODEL : IM-45CLE-25, IM-45CLE | | | | TITLE : C. ICE MAKING MECHANISM ASSY | | | |
|-------------------------------|------------------------------------|--------------------------|-------------|--------------------------------------|-------------------|-------------------|------------|
| INDEX NO. | DESCRIPTION | MATERIAL OR MODEL NUMBER | PART NUMBER | REQ'D NUMBER | | | |
| | | | | H-1 J-0 K-0 | K-1 A-0 B-0 | B-1 C-0 D-0 | D-1 E-0 |
| J | BIN CONTROL SWITCH ASSY | (S-9022) | 3H1537A08 | 1 | 1 | 1 | 1 |
| K | WATER PAN ASSY | (IM-45CLE-25) | 2H1158A03 | 1 | — | | |
| | | | 2H1158A06 | | 1 | 1 | 1 |
| | WATER PAN ASSY | (IM-45CLE) | 2H1158A02 | 1 | 1 | 1 | 1 |
| 1 | ACTUATOR MOTOR | SR486A43-12 | 457880-01 | 1 | 1 | 1 | 1 |
| 2 | BRACKET - ACTUATOR MOTOR | G.S | 3H1388-01 | 1 | 1 | 1 | 1 |
| 3 | CAM (A) | AC | 2H0659-01 | 1 | 1 | 1 | 1 |
| 4 | CAM (B) | AC | 3H1389-01 | 1 | 1 | 1 | 1 |
| 5 | CAM SHAFT | S.S | 4H2589G01 | 1 | 1 | 1 | 1 |
| 6 | SPRING | S.S | 4H2640-01 | 2 | 2 | 2 | 2 |
| 7 | TOGGLE SWITCH | VAT4-71 | 431977-01 | 1 | 1 | 1 | 1 |
| 8 | WASHER - TOGGLE SWITCH | S.S | 406196-01 | 1 | 1 | 1 | 1 |
| 9 | HANGER BRACKET (FRONT) - WATER PAN | | 4H2591G01 | 1 | 1 | 1 | 1 |
| 10 | HANGER BRACKET (REAR) - WATER PAN | | 4H2592G01 | 1 | 1 | 1 | 1 |
| 11 | CAM SHAFT HOLDER | | 307256-01 | 1 | 1 | 1 | 1 |
| 12 | SPACER | (IM-45CLE-25) | 4X5342-01 | 4 | 4 | 4 | 4 |
| | SPACER | (IM-45CLE) | 4H0471-01 | 4 | 4 | 4 | 4 |
| 13 | SCREW EVAPORATOR | (IM-45CLE-25) | 4Y4922M02 | 4 | 4 | 4 | 4 |
| | SCREW - EVAPORATOR MOUNTING | (IM-45CLE) | 4H2593-01 | 4 | 4 | 4 | 4 |
| 14 | INSULATION (D) | | 4X4013-02 | 1 | 1 | 1 | 1 |
| 15 | CLAMP | No. 2674 | 427902-02 | 1 | 1 | 1 | 1 |
| 16 | BRACKET - ICE MAKING MECHANISM | (IM-45CLE-25) | 3X1625-01 | 1 | 1 | 1 | 1 |
| | BRACKET - ICE MAKING MECHANISM | (IM-45CLE) | 3X1647-01 | 1 | 1 | 1 | 1 |
| 17 | WASHER | | 4H0777-01 | 4 | 4 | 4 | 4 |
| 18 | SWITCH COVER | PE | 408163-01 | 1 | 1 | 1 | 1 |
| 19 | SPRING PIN | S.S, 3x22 | 712S-0322 | 1 | 1 | 1 | 1 |
| 20 | TIE | CV-100 | 7920-0002 | 2 | 2 | 2 | 2 |
| 21 | THERMISTOR | NBFC-36-AH1-2 | 462976-02 | 1 | 1 | 1 | 1 |
| 22 | HOLDER - THERMISTOR | PE | 3H9642-01 | 1 | 1 | 1 | 1 |
| 23 | SPLIT PIN | S.S, 2x12 | 711S-0212 | 1 | 1 | 1 | 1 |
| 24 | HOLDER | 575 | 428644-02 | 1 | 1 | 1 | 1 |
| | | | | | | | |
| | | | | | | | |

HE, GENERAL(50Hz), EXPORT(60Hz), AUSTRALIA, OCEANIA, HSP,KOREA

| MODEL : IM-45CLE-25, IM-45CLE | | | | TITLE : C. ICE MAKING MECHANISM ASSY | | | |
|-------------------------------|------------------------------------|--------------------------|-------------|--------------------------------------|-------------------|-----|------------|
| INDEX NO. | DESCRIPTION | MATERIAL OR MODEL NUMBER | PART NUMBER | REQ'D NUMBER | | | |
| | | | | E-1 | E-2 F-0 G-0 | G-1 | G-2 T-0 |
| J | BIN CONTROL SWITCH ASSY | (S-9022) | 3H1537A08 | 1 | 1 | 1 | 1 |
| K | WATER PAN ASSY | (IM-45CLE-25) | - | | | | |
| | WATER PAN ASSY | (IM-45CLE) | 2H1158A06 | 1 | 1 | 1 | 1 |
| | WATER PAN ASSY | (IM-45CLE) | 2H1158A02 | 1 | 1 | 1 | 1 |
| 1 | ACTUATOR MOTOR | SR486A43-12 | 457880-01 | 1 | 1 | 1 | 1 |
| 2 | BRACKET - ACTUATOR MOTOR | G.S | 3H1388-01 | 1 | 1 | 1 | 1 |
| 3 | CAM (A) | AC | 2H0659-01 | 1 | 1 | 1 | 1 |
| 4 | CAM (B) | AC | 3H1389-01 | 1 | 1 | 1 | 1 |
| 5 | CAM SHAFT | S.S | 4H2589G01 | 1 | 1 | 1 | 1 |
| 6 | SPRING | S.S | 4H2640-01 | 2 | 2 | 2 | 2 |
| 7 | TOGGLE SWITCH | VAT4-71 | 431977-01 | 1 | 1 | 1 | 1 |
| 8 | WASHER - TOGGLE SWITCH | S.S | 406196-01 | 1 | 1 | 1 | 1 |
| 9 | HANGER BRACKET (FRONT) - WATER PAN | | 4H2591G01 | 1 | 1 | 1 | 1 |
| 10 | HANGER BRACKET (REAR) - WATER PAN | | 4H2592G01 | 1 | 1 | 1 | 1 |
| 11 | CAM SHAFT HOLDER | | 307256-01 | 1 | 1 | 1 | 1 |
| 12 | SPACER | (IM-45CLE-25) | 4X5342-01 | 4 | 4 | 4 | 4 |
| | SPACER | (IM-45CLE) | 4H0471-01 | 4 | 4 | 4 | 4 |
| 13 | SCREW EVAPORATOR | (IM-45CLE-25) | 4Y4922M02 | 4 | 4 | 4 | 4 |
| | SCREW - EVAPORATOR MOUNTING | (IM-45CLE) | 4H2593-01 | 4 | 4 | 4 | 4 |
| 14 | INSULATION (D) | | 4X4013-02 | 1 | 1 | 1 | 1 |
| 15 | CLAMP | No. 2674 | 427902-02 | 1 | 1 | 1 | 1 |
| 16 | BRACKET - ICE MAKING MECHANISM | (IM-45CLE-25) | 3X1625-01 | 1 | 1 | 1 | 1 |
| | BRACKET - ICE MAKING MECHANISM | (IM-45CLE) | 3X1647-01 | 1 | 1 | 1 | 1 |
| 17 | WASHER | | 4H0777-01 | 4 | 4 | 4 | 4 |
| 18 | SWITCH COVER | PE | 408163-01 | 1 | 1 | 1 | 1 |
| 19 | SPRING PIN | S.S, 3x22 | 712S-0322 | 1 | 1 | 1 | 1 |
| 20 | TIE | CV-100 | 7920-0002 | 2 | 2 | 2 | 2 |
| 21 | THERMISTOR | NBFC-36-AH1-2 | 462976-02 | 1 | 1 | 1 | 1 |
| 22 | HOLDER - THERMISTOR | PE | 3H9642-01 | 1 | 1 | 1 | 1 |
| 23 | SPLIT PIN | S.S, 2x12 | 711S-0212 | 1 | 1 | 1 | 1 |
| 24 | HOLDER | 575 | 428644-02 | 1 | 1 | 1 | 1 |
| | | | | | | | |
| | | | | | | | |

HE, GENERAL(50Hz), EXPORT(60Hz), AUSTRALIA, OCEANIA, HSP,KOREA,CHINA

| MODEL : IM-45CLE-25, IM-45CLE | | TITLE : C. ICE MAKING MECHANISM ASSY | | | | | |
|-------------------------------|------------------------------------|--------------------------------------|-------------|--------------------|--|--|--|
| INDEX NO. | DESCRIPTION | MATERIAL OR MODEL NUMBER | PART NUMBER | REQ'D NUMBER | | | |
| | | | | T-1,U-0 V-0,L-0 | | | |
| J | BIN CONTROL SWITCH ASSY | (S-9022) | 3H1537A08 | 1 | | | |
| K | WATER PAN ASSY | (IM-45CLE-25) | 2H1158A06 | 1 | | | |
| | WATER PAN ASSY | (IM-45CLE) | 2H1158A02 | 1 | | | |
| 1 | ACTUATOR MOTOR | SR486A43-12 | 457880-01 | 1 | | | |
| 2 | BRACKET - ACTUATOR MOTOR | G.S | 3H1388-01 | 1 | | | |
| 3 | CAM (A) | AC | 2H0659-01 | 1 | | | |
| 4 | CAM (B) | AC | 3H1389-01 | 1 | | | |
| 5 | CAM SHAFT | S.S | 4H2589G01 | 1 | | | |
| 6 | SPRING | S.S | 4H2640-01 | 2 | | | |
| 7 | TOGGLE SWITCH | VAT4-71 | 431977-01 | 1 | | | |
| 8 | WASHER - TOGGLE SWITCH | S.S | 406196-01 | 1 | | | |
| 9 | HANGER BRACKET (FRONT) - WATER PAN | | 4H2591G01 | 1 | | | |
| 10 | HANGER BRACKET (REAR) - WATER PAN | | 4H2592G01 | 1 | | | |
| 11 | CAM SHAFT HOLDER | | 307256-01 | 1 | | | |
| 12 | SPACER | (IM-45CLE-25) | 4X5342-01 | 4 | | | |
| | SPACER | (IM-45CLE) | 4H0471-01 | 4 | | | |
| 13 | SCREW EVAPORATOR | (IM-45CLE-25) | 4Y4922M02 | 4 | | | |
| | SCREW - EVAPORATOR MOUNTING | (IM-45CLE) | 4H2593-01 | 4 | | | |
| 14 | INSULATION (D) | | 4X4013-02 | 1 | | | |
| 15 | CLAMP | No. 2674 | 427902-02 | 1 | | | |
| 16 | BRACKET - ICE MAKING MECHANISM | (IM-45CLE-25) | 3X1625-01 | 1 | | | |
| | BRACKET - ICE MAKING MECHANISM | (IM-45CLE) | 3X1647-01 | 1 | | | |
| 17 | WASHER | | 4H0777-01 | 4 | | | |
| 18 | SWITCH COVER | PE | 408163-01 | 1 | | | |
| 19 | SPRING PIN | S.S, 3x22 | 712S-0322 | 1 | | | |
| 20 | TIE | CV-100 | 7920-0002 | 2 | | | |
| 21 | THERMISTOR | NBFC-36-AH1-2 | 462976-02 | 1 | | | |
| 22 | HOLDER - THERMISTOR | PE | 3H9642-01 | 1 | | | |
| 23 | SPLIT PIN | S.S, 2x12 | 711S-0212 | 1 | | | |
| 24 | HOLDER | 575 | 428644-02 | 1 | | | |
| | | | | | | | |
| | | | | | | | |
| | | | | | | | |

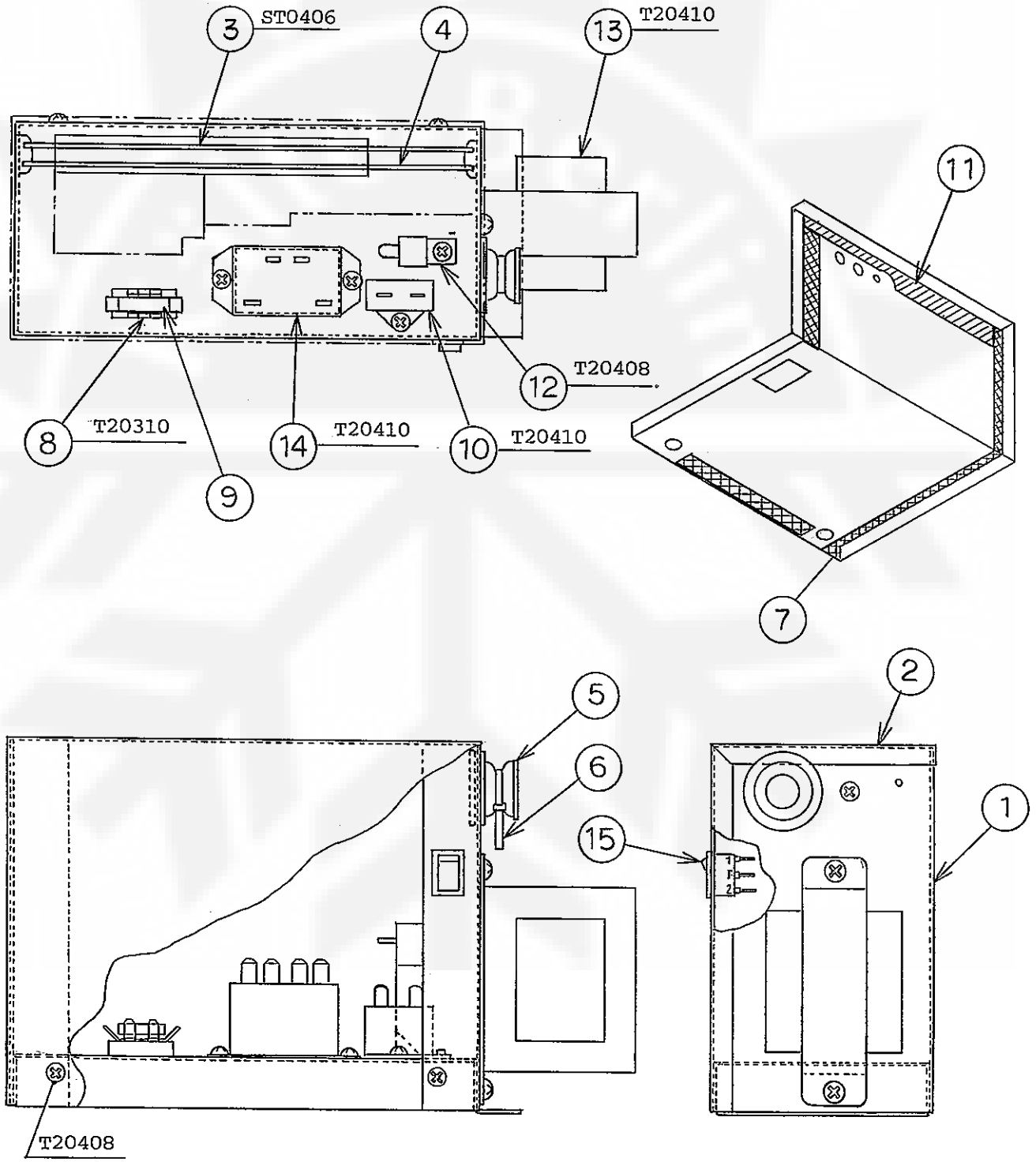

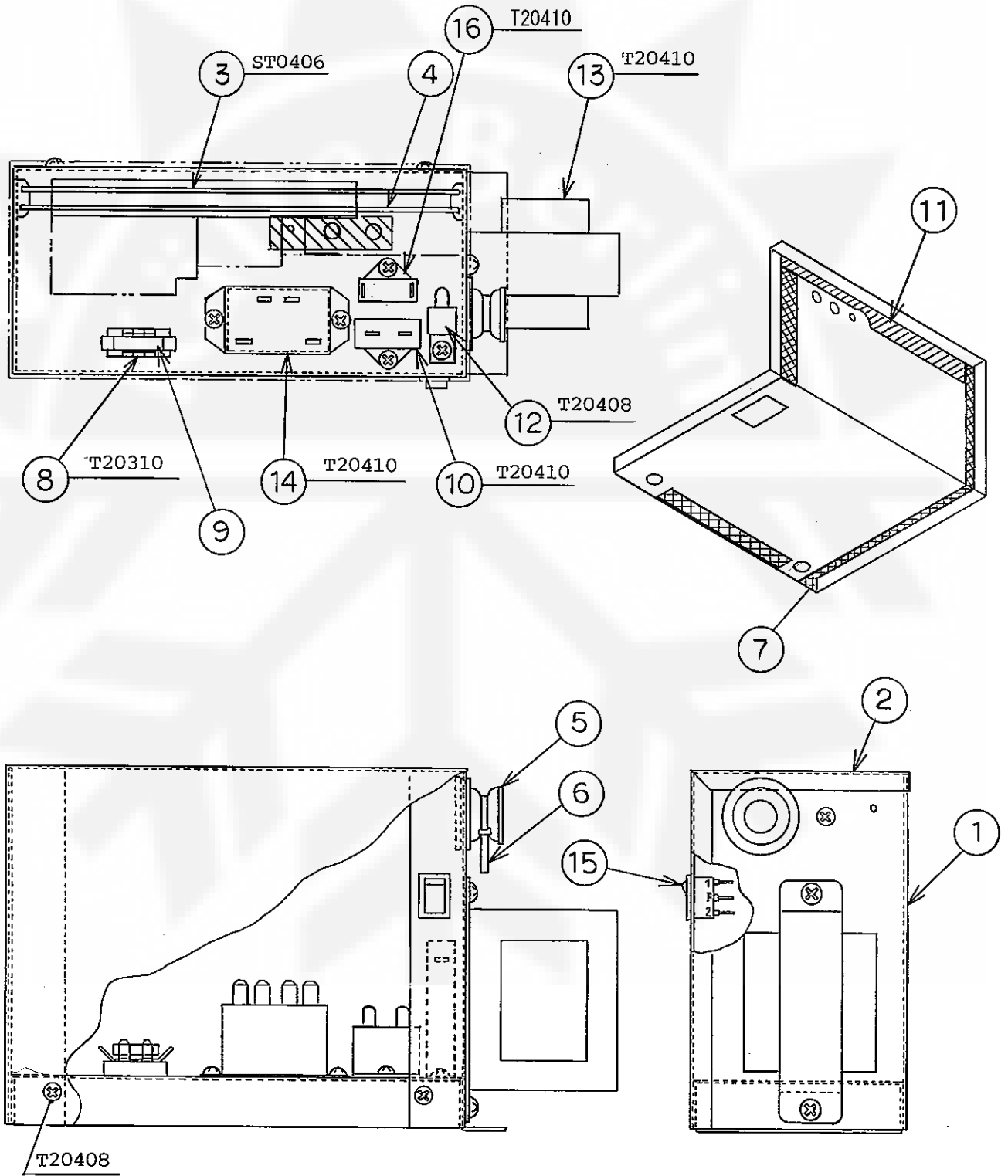

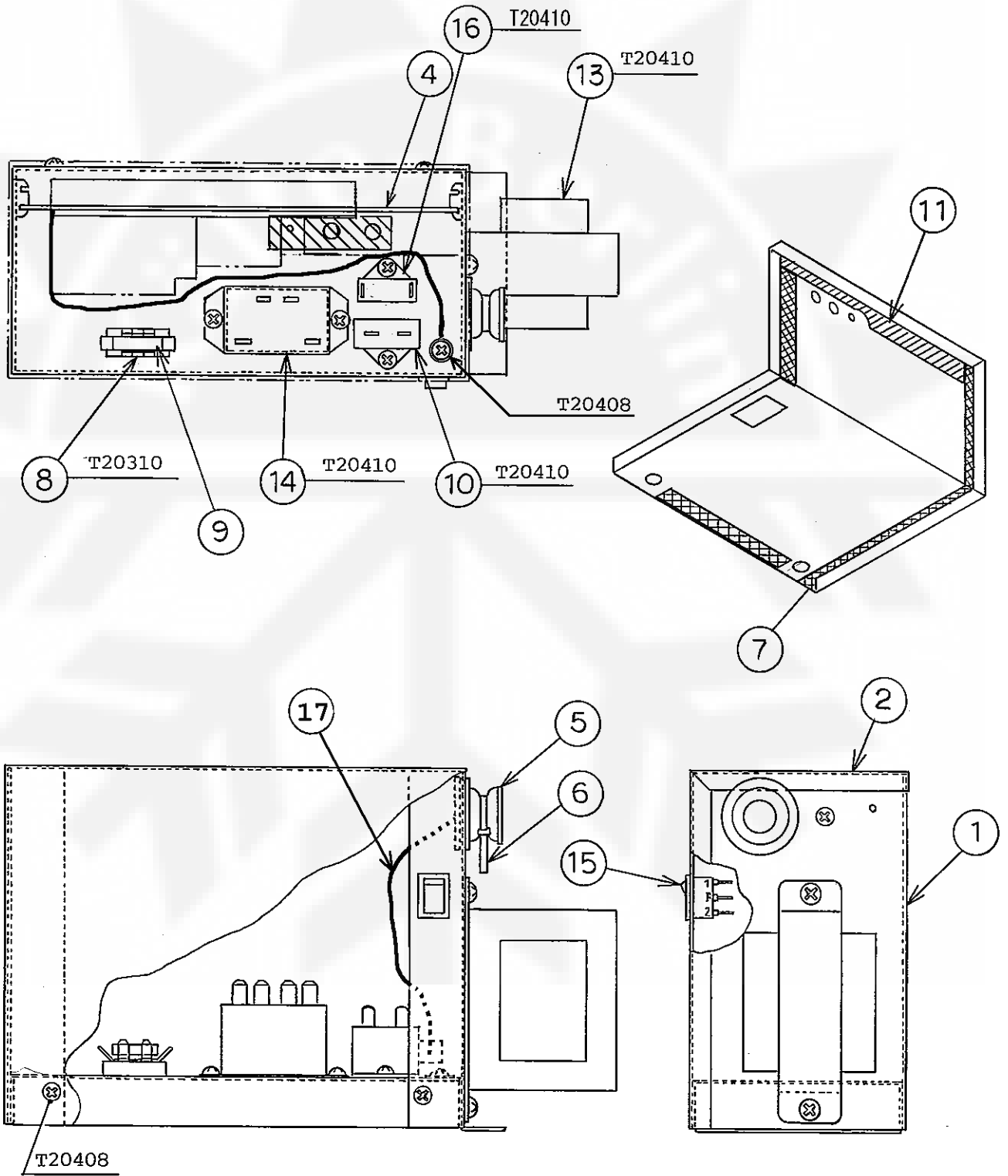

HE, GENERAL(50Hz), EXPORT(60Hz), AUSTRALIA, OCEANIA, HSP,KOREA

| MODEL : IM-45CLE-25, IM-45CLE | | | | TITLE : D. CONTROL BOX ASSY | | | |
|--------------------------------------|----------------------------|--------------------------|-------------|------------------------------------|-------------------|-------------------|------------|
| INDEX NO. | DESCRIPTION | MATERIAL OR MODEL NUMBER | PART NUMBER | REQ'D NUMBER | | | |
| | | | | H-1 J-0 K-0 | K-1 A-0 B-0 | B-1 C-0 D-0 | D-1 E-0 |
| 1 | CONTROL BOX | G.S | 3X1643G01 | 1 | 1 | 1 | — |
| | | G.S | 3X1643G02 | | | | 1 |
| 2 | CONTROL BOX COVER | G.S | 4X1623-01 | 1 | 1 | 1 | 1 |
| 3 | SHIELD PLATE | G.S | 4H2594-01 | 1 | 1 | 1 | 1 |
| 4 | CONTROLLER BOARD | H2AA136C10 | 436572-10 | 1 | 1 | 1 | 1 |
| | | H2AE024C18 | 462975-18 | | | | |
| 5 | GROMMET | NBR | 4H2568-01 | 1 | 1 | 1 | 1 |
| 6 | NYLON TIE | PRT1.5S | 427466-01 | 1 | 1 | 1 | 1 |
| 7 | SEAL TAPE | w8 x t3.2 | 2H3637-11 | 1 | 1 | 1 | 1 |
| | | w8 x t3.2 | 2H6751-07 | | | | |
| 8 | FUSE HOLDER | 445710 | 451925-01 | 1 | 1 | 1 | — |
| | | CFH15 | 4Y2547-01 | | | | 1 |
| 9 | FUSE | 5A | 451924-01 | 1 | 1 | 1 | 1 |
| 10 | CAPACITOR - ACTUATOR MOTOR | UJ25B804UXF | 456262-01 | 1 | 1 | 1 | 1 |
| 11 | CUSHION | 25 x 210 x 2.5t, PE | 4H2718-01 | 1 | 1 | 1 | 1 |
| 12 | SURGE ABSORBER | - | 436573-02 | 1 | 1 | 1 | 1 |
| 13 | TRANSFORMER | 230V / 100V | 450104-01 | 1 | 1 | 1 | 1 |
| 14 | POWER RELAY | G7L-1A-TUB | 449000-01 | 1 | 1 | 1 | 1 |
| 15 | ROCKER SWITCH | H8600VB | 460681-01 | 1 | 1 | 1 | 1 |
| 16 | CAPACITOR - PUMP MOTOR | UJ20B105UWF | 457885-01 | | 1 | 1 | 1 |
| 17 | THERMISTOR-AMBIENT TEMP | 182-103-86742 | 462977-02 | | | | |
| | | | | | | | |
| | | | | | | | |
| | | | | | | | |
| | | | | | | | |
| | | | | | | | |
| | | | | | | | |
| | | | | | | | |
| | | | | | | | |
| | | | | | | | |
| | | | | | | | |
| | | | | | | | |
| | | | | | | | |
| | | | | | | | |

HE, GENERAL(50Hz), EXPORT(60Hz), AUSTRALIA, OCEANIA, HSP,KOREA

| MODEL : IM-45CLE-25, IM-45CLE | | | | TITLE : D. CONTROL BOX ASSY | | | |
|-------------------------------|----------------------------|--------------------------|-------------|-----------------------------|-------------------|-----|------------|
| INDEX NO. | DESCRIPTION | MATERIAL OR MODEL NUMBER | PART NUMBER | REQ'D NUMBER | | | |
| | | | | E-1 | E-2 F-0 G-0 | G-1 | G-2 T-0 |
| 1 | CONTROL BOX | - | - | | | | |
| | | G.S | 3X1643G02 | 1 | 1 | 1 | 1 |
| 2 | CONTROL BOX COVER | G.S | 4X1623-01 | 1 | 1 | 1 | 1 |
| 3 | SHIELD PLATE | G.S | 4H2594-01 | x | | | |
| 4 | CONTROLLER BOARD | H2AA136C10 | 436572-10 | - | | | |
| | | H2AE024C18 | 462975-18 | 1 | 1 | 1 | 1 |
| 5 | GROMMET | NBR | 4H2568-01 | 1 | 1 | 1 | 1 |
| 6 | NYLON TIE | PRT1.5S | 427466-01 | 1 | 1 | 1 | 1 |
| 7 | SEAL TAPE | w8 x t3.2 | 2H3637-11 | - | | | |
| | | w8 x t3.2 | 2H6751-07 | 1 | 1 | 1 | 1 |
| 8 | FUSE HOLDER | - | - | | | | |
| | | CFH15 | 4Y2547-01 | 1 | 1 | 1 | 1 |
| 9 | FUSE | 5A | 451924-01 | 1 | 1 | 1 | 1 |
| 10 | CAPACITOR - ACTUATOR MOTOR | UJ25B804UXF | 456262-01 | 1 | 1 | 1 | 1 |
| 11 | CUSHION | 25 x 210 x 2.5t, PE | 4H2718-01 | 1 | 1 | 1 | 1 |
| 12 | SURGE ABSORBER | - | 436573-02 | x | | | |
| 13 | TRANSFORMER | 230V / 100V | 450104-01 | 1 | 1 | 1 | 1 |
| 14 | POWER RELAY | G7L-1A-TUB | 449000-01 | 1 | 1 | 1 | 1 |
| 15 | ROCKER SWITCH | H8600VB | 460681-01 | 1 | 1 | 1 | 1 |
| 16 | CAPACITOR - PUMP MOTOR | UJ20B105UWF | 457885-01 | 1 | 1 | 1 | 1 |
| 17 | THERMISTOR-AMBIENT TEMP | 182-103-86742 | 462977-02 | 1 | 1 | 1 | 1 |
| | | | | | | | |
| | | | | | | | |
| | | | | | | | |
| | | | | | | | |
| | | | | | | | |
| | | | | | | | |
| | | | | | | | |
| | | | | | | | |
| | | | | | | | |
| | | | | | | | |
| | | | | | | | |
| | | | | | | | |
| | | | | | | | |
| | | | | | | | |
| | | | | | | | |
| | | | | | | | |

HE, GENERAL(50Hz), EXPORT(60Hz), AUSTRALIA, OCEANIA, HSP,KOREA,CHINA

| MODEL : IM-45CLE-25, IM-45CLE | | | | TITLE : D. CONTROL BOX ASSY | | | |
|-------------------------------|----------------------------|--------------------------|-------------|-----------------------------|--|--|--|
| INDEX NO. | DESCRIPTION | MATERIAL OR MODEL NUMBER | PART NUMBER | REQ'D NUMBER | | | |
| | | | | T-1,U-0 V-0,L-0 | | | |
| 1 | CONTROL BOX | G.S | 3X1643G02 | 1 | | | |
| 2 | CONTROL BOX COVER | G.S | 4X1623-01 | 1 | | | |
| 3 | SHIELD PLATE | G.S | 4H2594-01 | | | | |
| 4 | CONTROLLER BOARD | H2AE024C18 | 462975-18 | 1 | | | |
| 5 | GROMMET | NBR | 4H2568-01 | 1 | | | |
| 6 | NYLON TIE | PRT1.5S | 427466-01 | 1 | | | |
| 7 | SEAL TAPE | w8 x t3.2 | 2H6751-07 | 1 | | | |
| 8 | FUSE HOLDER | CFH15 | 4Y2547-01 | 1 | | | |
| 9 | FUSE | 5A | 451924-01 | 1 | | | |
| 10 | CAPACITOR - ACTUATOR MOTOR | UJ25B804UXF | 456262-01 | 1 | | | |
| 11 | CUSHION | 25 x 210 x 2.5t, PE | 4H2718-01 | 1 | | | |
| 12 | - | - | - | | | | |
| 13 | TRANSFORMER | 230V / 100V | 450104-01 | 1 | | | |
| 14 | POWER RELAY | G7L-1A-TUB | 449000-01 | 1 | | | |
| 15 | ROCKER SWITCH | H8600VB | 460681-01 | 1 | | | |
| 16 | CAPACITOR - PUMP MOTOR | UJ20B105UWF | 457885-01 | 1 | | | |
| 17 | THERMISTOR-AMBIENT TEMP | 182-103-86742 | 462977-02 | 1 | | | |
| | | | | | | | |
| | | | | | | | |
| | | | | | | | |
| | | | | | | | |
| | | | | | | | |
| | | | | | | | |
| | | | | | | | |
| | | | | | | | |
| | | | | | | | |
| | | | | | | | |
| | | | | | | | |
| | | | | | | | |
| | | | | | | | |
| | | | | | | | |
| | | | | | | | |
| | | | | | | | |
| | | | | | | | |
| | | | | | | | |
| | | | | | | | |
| | | | | | | | |
| | | | | | | | |
| | | | | | | | |
| | | | | | | | |
| | | | | | | | |
| | | | | | | | |
| | | | | | | | |

IM-45CLE-25
IM-45CLE

E. DOOR ASSY

(E-2) (F-0) (G-0) (G-1)
(D-0) (D-1) (E-0) (E-1)
(A-0) (B-0) (B-1) (C-0)
(H-1) (J-0) (K-0) (K-1)

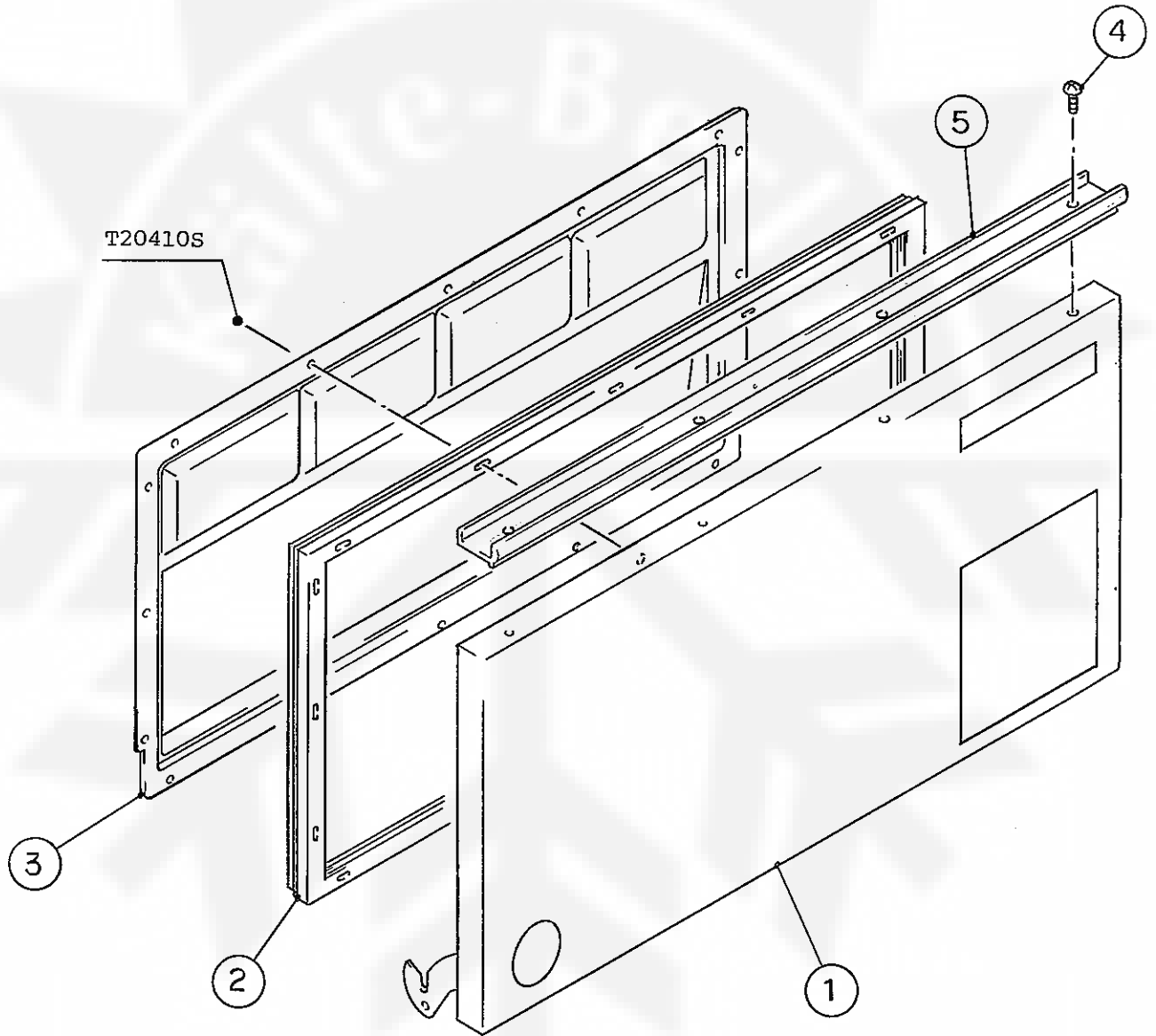

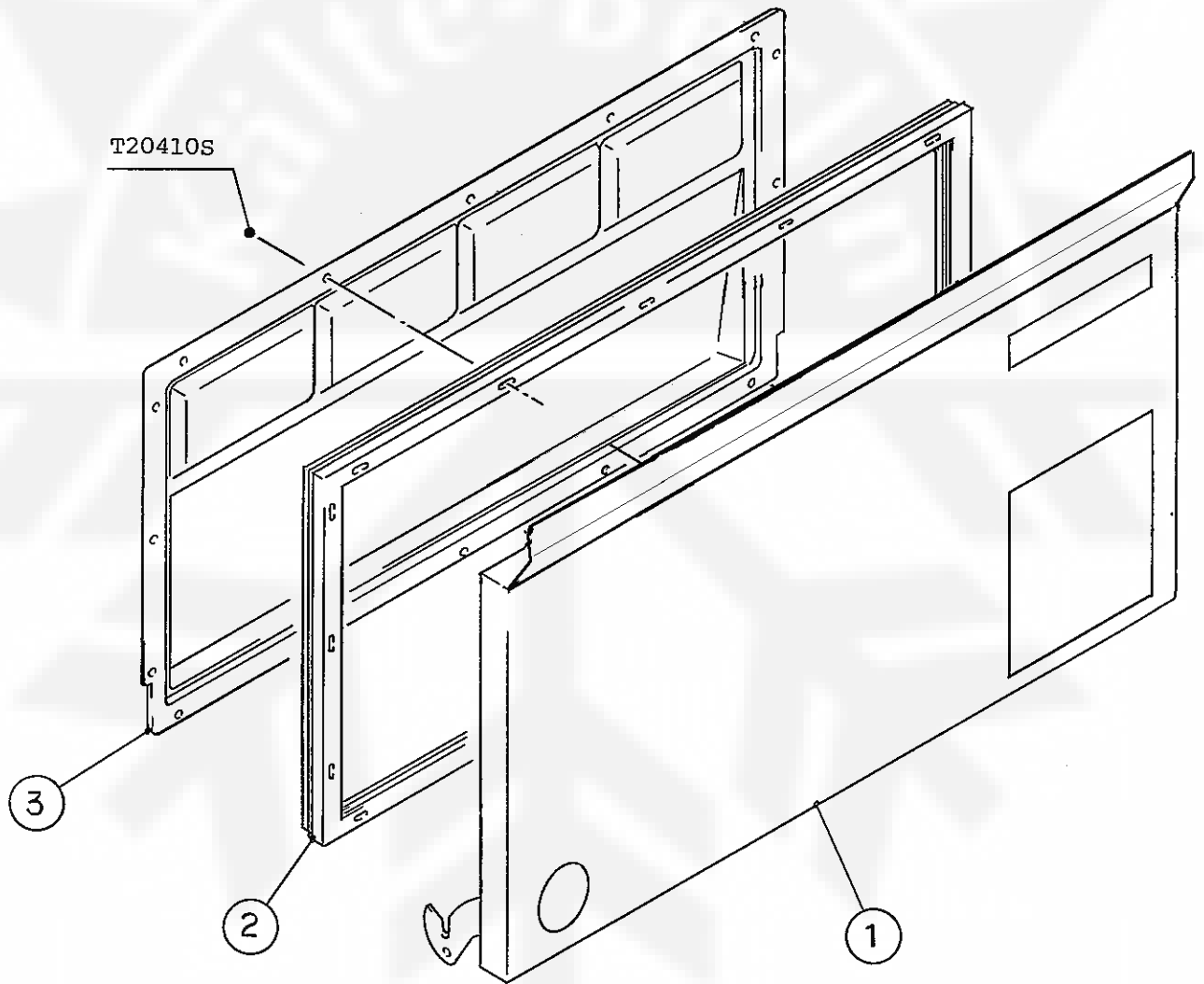

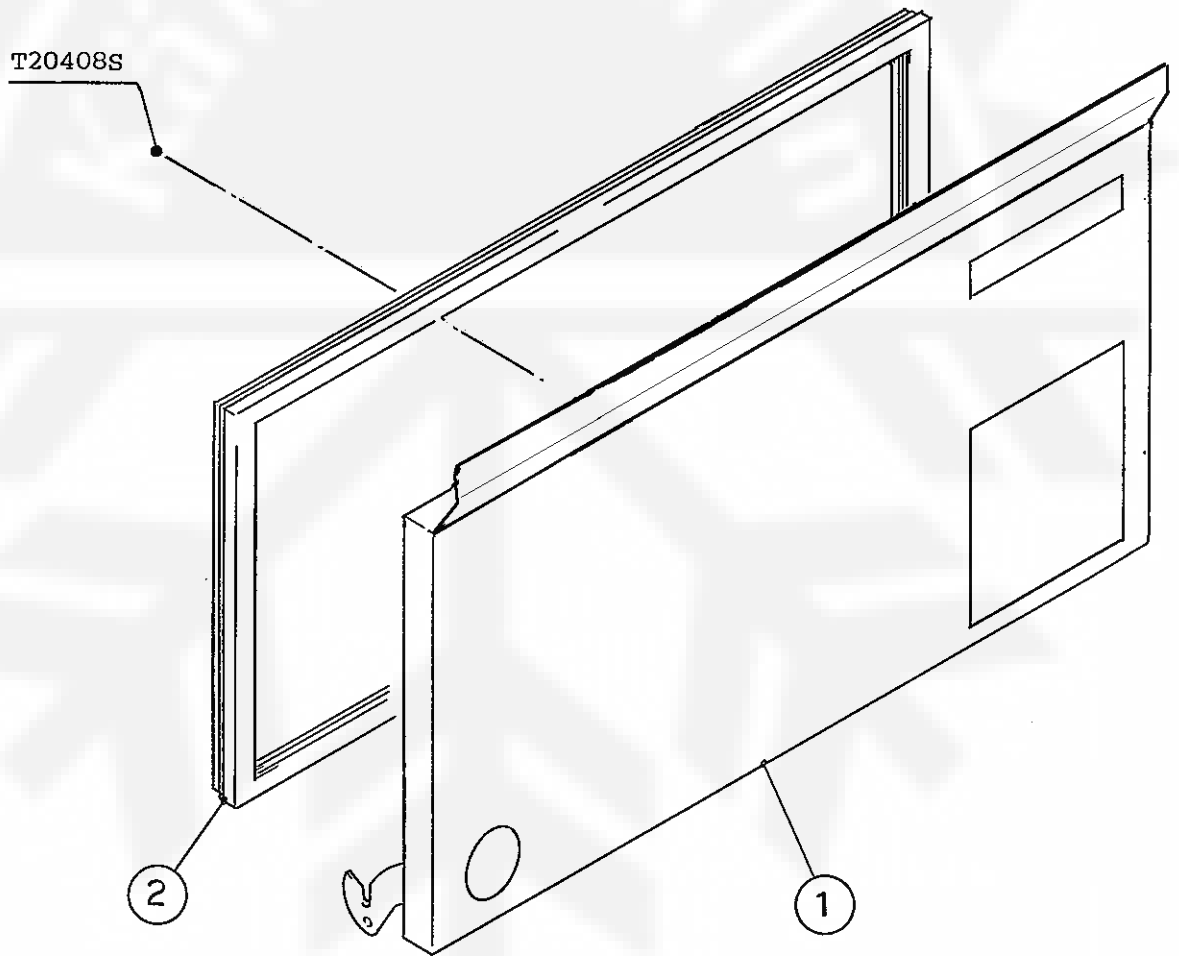

HE, GENERAL(50Hz), EXPORT(60Hz), AUSTRALIA, OCEANIA, HSP,KOREA

| MODEL : IM-45CLE-25, IM-45CLE | | | | TITLE : E. DOOR ASSY | | | |
|-------------------------------|-----------------------|--------------------------|-------------|----------------------|-------------------|-------------------|------------|
| INDEX NO. | DESCRIPTION | MATERIAL OR MODEL NUMBER | PART NUMBER | REQ'D NUMBER | | | |
| | | | | H-1 J-0 K-0 | K-1 A-0 B-0 | B-1 C-0 D-0 | D-1 E-0 |
| 1 | DOOR | S.S | 3X2030G01 | 1 | 1 | 1 | 1 |
| | | S.S | 3Y2780G01 | | | | |
| | | S.S | 3Y2904G01 | | | | |
| 2 | GASKET | PVC RUBBER | 3H0161-03 | 1 | 1 | 1 | 1 |
| | | PVC RUBBER | 3X3545-03 | | | | |
| 3 | REVERSE COVER | ABS | 3H0157-01 | 1 | 1 | 1 | 1 |
| 4 | TAPPING SCREW (BLACK) | STEEL, 4x8 | 433954-01 | 3 | 3 | 3 | 3 |
| 5 | HANDLE | ABS | 328924-03 | 1 | 1 | 1 | 1 |
| | | | | | | | |
| | | | | | | | |
| | | | | | | | |
| | | | | | | | |
| | | | | | | | |
| | | | | | | | |
| | | | | | | | |
| | | | | | | | |
| | | | | | | | |
| | | | | | | | |
| | | | | | | | |
| | | | | | | | |
| | | | | | | | |
| | | | | | | | |
| | | | | | | | |
| | | | | | | | |
| | | | | | | | |
| | | | | | | | |
| | | | | | | | |
| | | | | | | | |
| | | | | | | | |
| | | | | | | | |
| | | | | | | | |
| | | | | | | | |
| | | | | | | | |
| | | | | | | | |
| | | | | | | | |
| | | | | | | | |
| | | | | | | | |
| | | | | | | | |
| | | | | | | | |
| | | | | | | | |
| | | | | | | | |
| | | | | | | | |
| | | | | | | | |
| | | | | | | | |
| | | | | | | | |
| | | | | | | | |
| | | | | | | | |

HE, GENERAL(50Hz), EXPORT(60Hz), AUSTRALIA, OCEANIA, HSP, KOREA

| MODEL : IM-45CLE-25, IM-45CLE | | | | TITLE : E. DOOR ASSY | | | |
|-------------------------------|-----------------------|--------------------------|-------------|----------------------|-------------------|-----|------------|
| INDEX NO. | DESCRIPTION | MATERIAL OR MODEL NUMBER | PART NUMBER | REQ'D NUMBER | | | |
| | | | | E-1 | E-2 F-0 G-0 | G-1 | G-2 T-0 |
| 1 | DOOR | S.S | 3X2030G01 | 1 | 1 | - | |
| | | S.S | 3Y2780G01 | | | 1 | - |
| | | S.S | 3Y2904G01 | | | | 1 |
| 2 | GASKET | PVC RUBBER | 3H0161-03 | 1 | 1 | 1 | - |
| | | PVC RUBBER | 3X3545-03 | | | | 1 |
| 3 | REVERSE COVER | ABS | 3H0157-01 | 1 | 1 | 1 | x |
| 4 | TAPPING SCREW (BLACK) | STEEL, 4x8 | 433954-01 | 3 | 3 | x | |
| 5 | HANDLE | ABS | 328924-03 | 1 | 1 | x | |
| | | | | | | | |
| | | | | | | | |
| | | | | | | | |
| | | | | | | | |
| | | | | | | | |
| | | | | | | | |
| | | | | | | | |
| | | | | | | | |
| | | | | | | | |
| | | | | | | | |
| | | | | | | | |
| | | | | | | | |
| | | | | | | | |
| | | | | | | | |
| | | | | | | | |
| | | | | | | | |
| | | | | | | | |
| | | | | | | | |
| | | | | | | | |
| | | | | | | | |
| | | | | | | | |
| | | | | | | | |
| | | | | | | | |
| | | | | | | | |
| | | | | | | | |
| | | | | | | | |

HE, GENERAL(50Hz), EXPORT(60Hz), AUSTRALIA, OCEANIA, HSP,KOREA,CHINA

| MODEL : IM-45CLE-25, IM-45CLE | | TITLE : E. DOOR ASSY | | | | | |
|-------------------------------|-------------|--------------------------|-------------|--------------------|--|--|--|
| INDEX NO. | DESCRIPTION | MATERIAL OR MODEL NUMBER | PART NUMBER | REQ'D NUMBER | | | |
| | | | | T-1,U-0 V-0,L-0 | | | |
| 1 | DOOR | S.S | 3Y2904G01 | 1 | | | |
| 2 | GASKET | PVC RUBBER | 3X3545-03 | 1 | | | |
| 3 | - | - | - | | | | |
| 4 | - | - | - | | | | |
| 5 | - | - | - | | | | |
| | | | | | | | |
| | | | | | | | |
| | | | | | | | |
| | | | | | | | |
| | | | | | | | |
| | | | | | | | |
| | | | | | | | |
| | | | | | | | |
| | | | | | | | |
| | | | | | | | |
| | | | | | | | |
| | | | | | | | |
| | | | | | | | |
| | | | | | | | |
| | | | | | | | |
| | | | | | | | |
| | | | | | | | |
| | | | | | | | |
| | | | | | | | |
| | | | | | | | |
| | | | | | | | |
| | | | | | | | |
| | | | | | | | |
| | | | | | | | |
| | | | | | | | |
| | | | | | | | |
| | | | | | | | |
| | | | | | | | |
| | | | | | | | |

IM-45CLE-25
IM-45CLE

F. WATER CIRCUIT

(D-0) (D-1) (E-0) (E-1) and later
(A-0) (B-0) (B-1) (C-0)
(H-1) (J-0) (K-0) (K-1)

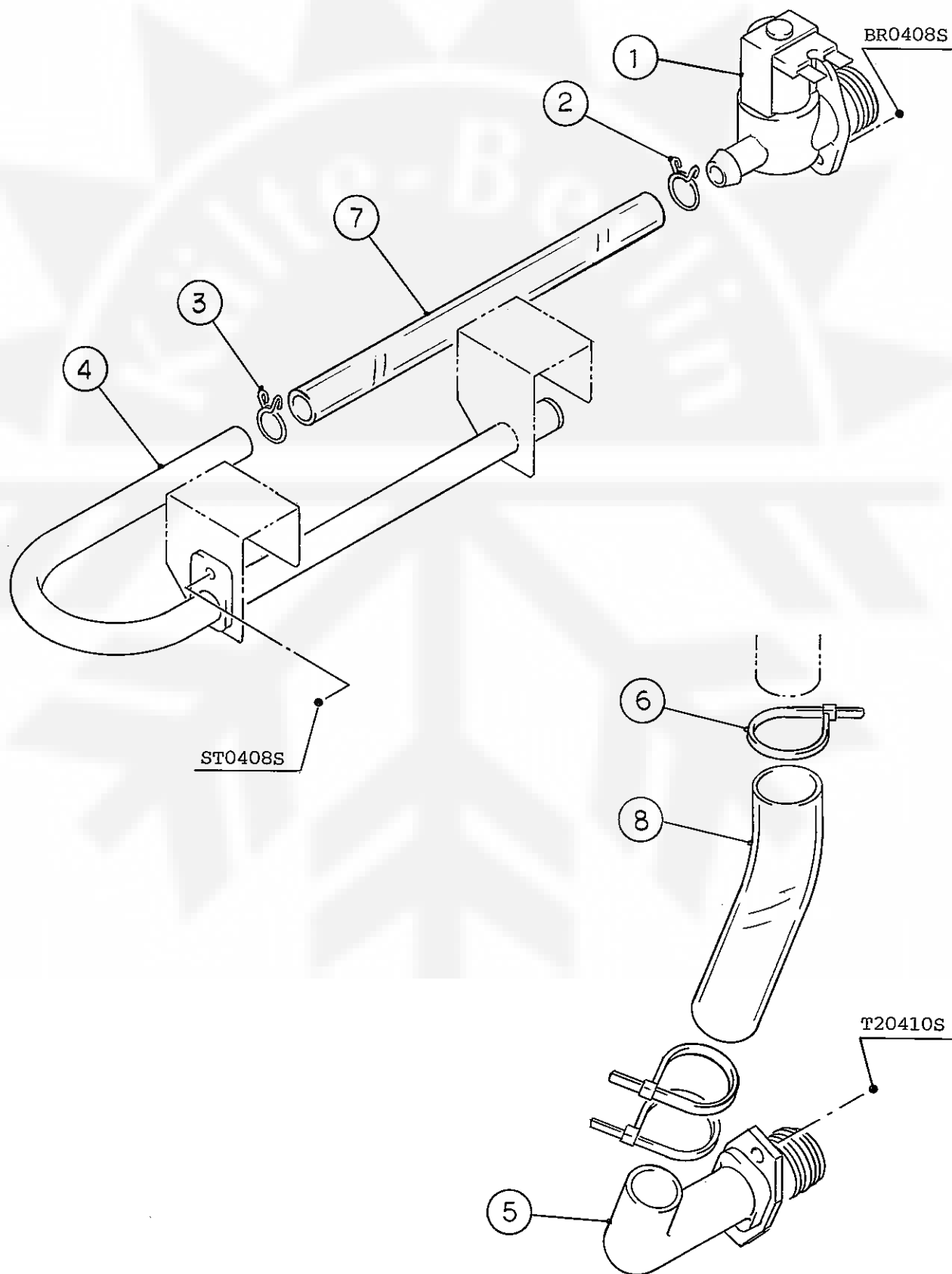

HE, GENERAL(50Hz), EXPORT(60Hz), AUSTRALIA, OCEANIA, HSP, KOREA

| MODEL : IM-45CLE-25, IM-45CLE | | | | TITLE : F. WATER CIRCUIT | | | |
|--------------------------------------|-------------------|--------------------------------|----------------|---------------------------------|-------------------|-------------------|------------|
| INDEX NO. | DESCRIPTION | MATERIAL OR MODEL NUMBER | PART NUMBER | REQ'D NUMBER | | | |
| | | | | H-1 J-0 K-0 | K-1 A-0 B-0 | B-1 C-0 D-0 | D-1 E-0 |
| 1 | WATER VALVE | V18, 3.8 lit./min. | 452138-01 | 1 | 1 | 1 | 1 |
| 2 | CLAMP | SK-15 | 435934-03 | 1 | 1 | 1 | 1 |
| 3 | CLAMP | SK-14 | 433909-01 | 1 | 1 | 1 | 1 |
| 4 | WATER SUPPLY PIPE | - | 3H9530G01 | 1 | 1 | 1 | 1 |
| 5 | DRAIN PIPE | PVC | 3H0394-01 | 1 | 1 | 1 | 1 |
| 6 | TIE | CV-150 | 7920-0003 | 3 | 3 | 3 | 3 |
| 7 | SILICONE HOSE | 12 ID x 15 OD L=270 | 3H9600-03 | 1 | 1 | 1 | 1 |
| 8 | VINYL HOSE | 22 ID x 26 OD L=125 | 7711-2226 | 1 | 1 | 1 | 1 |
| | | | | | | | |
| | | | | | | | |
| | | | | | | | |
| | | | | | | | |
| | | | | | | | |
| | | | | | | | |
| | | | | | | | |
| | | | | | | | |
| | | | | | | | |
| | | | | | | | |
| | | | | | | | |
| | | | | | | | |
| | | | | | | | |
| | | | | | | | |
| | | | | | | | |
| | | | | | | | |
| | | | | | | | |
| | | | | | | | |
| | | | | | | | |
| | | | | | | | |
| | | | | | | | |
| | | | | | | | |
| | | | | | | | |
| | | | | | | | |
| | | | | | | | |
| | | | | | | | |
| | | | | | | | |
| | | | | | | | |

HE, GENERAL(50Hz), EXPORT(60Hz), AUSTRALIA, OCEANIA, HSP,KOREA

| MODEL : IM-45CLE-25, IM-45CLE | | | | TITLE : F. WATER CIRCUIT | | | |
|-------------------------------|-------------------|--------------------------|-------------|--------------------------|-------------------|-----|------------|
| INDEX NO. | DESCRIPTION | MATERIAL OR MODEL NUMBER | PART NUMBER | REQ'D NUMBER | | | |
| | | | | E-1 | E-2 F-0 G-0 | G-1 | G-2 T-0 |
| 1 | WATER VALVE | V18, 3.8 lit./min. | 452138-01 | 1 | 1 | 1 | 1 |
| 2 | CLAMP | SK-15 | 435934-03 | 1 | 1 | 1 | 1 |
| 3 | CLAMP | SK-14 | 433909-01 | 1 | 1 | 1 | 1 |
| 4 | WATER SUPPLY PIPE | - | 3H9530G01 | 1 | 1 | 1 | 1 |
| 5 | DRAIN PIPE | PVC | 3H0394-01 | 1 | 1 | 1 | 1 |
| 6 | TIE | CV-150 | 7920-0003 | 3 | 3 | 3 | 3 |
| 7 | SILICONE HOSE | 12 ID x 15 OD L=270 | 3H9600-03 | 1 | 1 | 1 | 1 |
| 8 | VINYL HOSE | 22 ID x 26 OD L=125 | 7711-2226 | 1 | 1 | 1 | 1 |
| | | | | | | | |
| | | | | | | | |
| | | | | | | | |
| | | | | | | | |
| | | | | | | | |
| | | | | | | | |
| | | | | | | | |
| | | | | | | | |
| | | | | | | | |
| | | | | | | | |
| | | | | | | | |
| | | | | | | | |
| | | | | | | | |
| | | | | | | | |
| | | | | | | | |
| | | | | | | | |
| | | | | | | | |
| | | | | | | | |
| | | | | | | | |
| | | | | | | | |
| | | | | | | | |
| | | | | | | | |
| | | | | | | | |
| | | | | | | | |
| | | | | | | | |
| | | | | | | | |
| | | | | | | | |
| | | | | | | | |
| | | | | | | | |
| | | | | | | | |
| | | | | | | | |
| | | | | | | | |
| | | | | | | | |
| | | | | | | | |
| | | | | | | | |
| | | | | | | | |
| | | | | | | | |
| | | | | | | | |
| | | | | | | | |
| | | | | | | | |
| | | | | | | | |
| | | | | | | | |

HE, GENERAL(50Hz), EXPORT(60Hz), AUSTRALIA, OCEANIA, HSP,KOREA,CHINA

| MODEL : IM-45CLE-25, IM-45CLE | | TITLE : F. WATER CIRCUIT | | | | | |
|-------------------------------|-------------------|--------------------------|-------------|--------------------|--|--|--|
| INDEX NO. | DESCRIPTION | MATERIAL OR MODEL NUMBER | PART NUMBER | REQ'D NUMBER | | | |
| | | | | T-1,U-0 V-0,L-0 | | | |
| 1 | WATER VALVE | V18, 3.8 lit./min. | 452138-01 | 1 | | | |
| 2 | CLAMP | SK-15 | 435934-03 | 1 | | | |
| 3 | CLAMP | SK-14 | 433909-01 | 1 | | | |
| 4 | WATER SUPPLY PIPE | - | 3H9530G01 | 1 | | | |
| 5 | DRAIN PIPE | PVC | 3H0394-01 | 1 | | | |
| 6 | TIE | CV-150 | 7920-0003 | 3 | | | |
| 7 | SILICONE HOSE | 12 ID x 15 OD L=270 | 3H9600-03 | 1 | | | |
| 8 | VINYL HOSE | 22 ID x 26 OD L=125 | 7711-2226 | 1 | | | |
| | | | | | | | |
| | | | | | | | |
| | | | | | | | |
| | | | | | | | |
| | | | | | | | |
| | | | | | | | |
| | | | | | | | |
| | | | | | | | |
| | | | | | | | |
| | | | | | | | |
| | | | | | | | |
| | | | | | | | |
| | | | | | | | |
| | | | | | | | |
| | | | | | | | |
| | | | | | | | |
| | | | | | | | |
| | | | | | | | |
| | | | | | | | |
| | | | | | | | |
| | | | | | | | |
| | | | | | | | |
| | | | | | | | |
| | | | | | | | |
| | | | | | | | |
| | | | | | | | |
| | | | | | | | |
| | | | | | | | |
| | | | | | | | |
| | | | | | | | |

IM-45CLE-25
IM-45CLE

G. LABEL LOCATION

(D-0) (D-1) (E-0) (E-1) and later
(A-0) (B-0) (B-1) (C-0)
(H-1) (J-0) (K-0) (K-1)

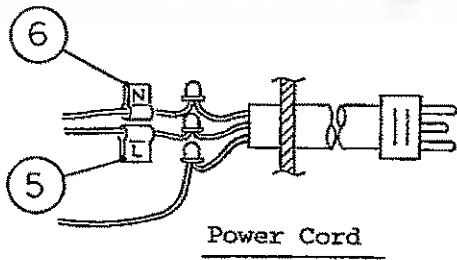
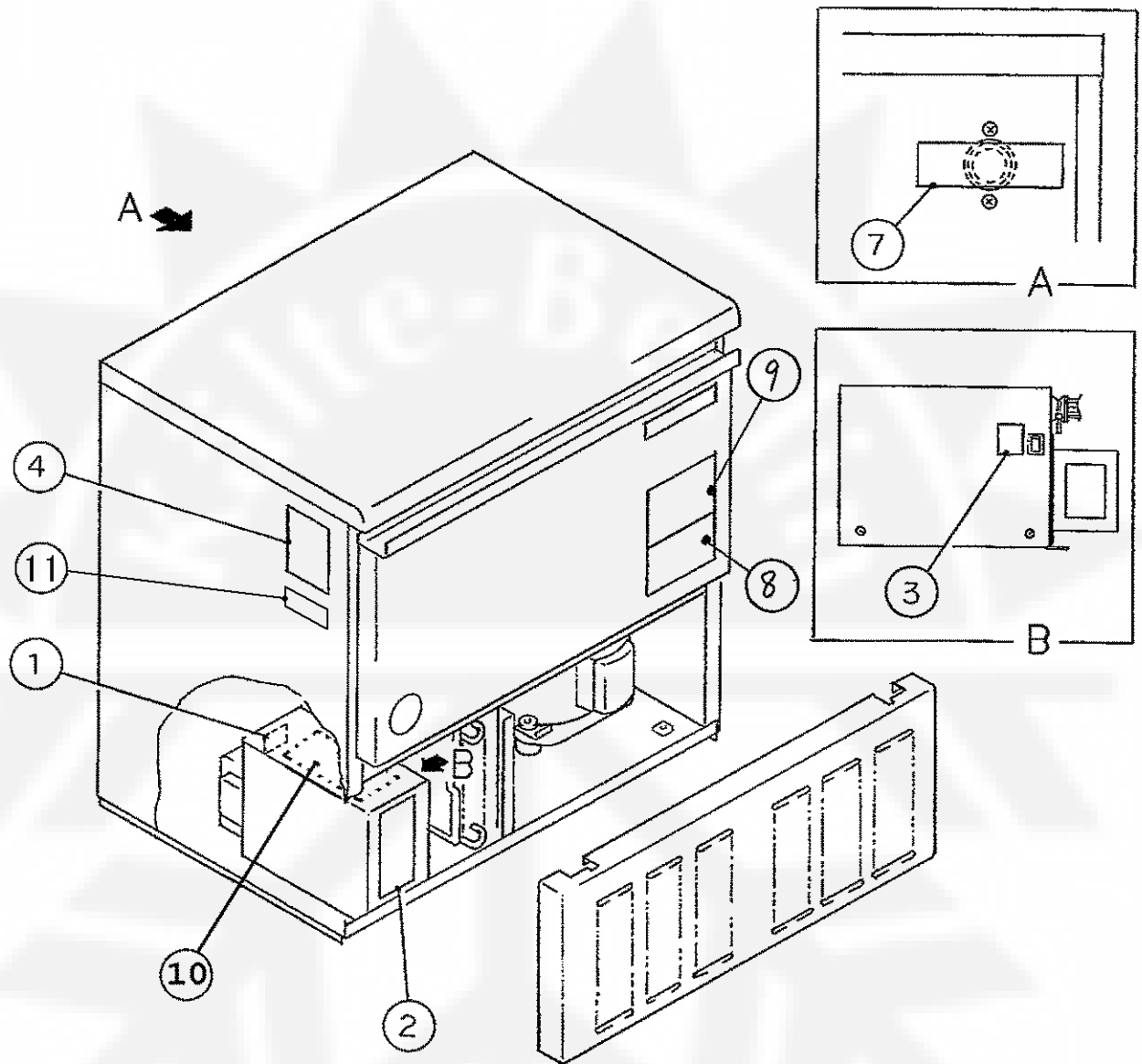

HE, GENERAL(50Hz), EXPORT(60Hz), AUSTRALIA, OCEANIA, HSP,KOREA

| MODEL : IM-45CLE-25, IM-45CLE | | | | TITLE : G. LABEL LOCATION | | | |
|-------------------------------|------------------|--|-------------|---------------------------|-------------------|-------------------|------------|
| INDEX NO. | DESCRIPTION | MATERIAL OR MODEL NUMBER | PART NUMBER | REQ'D NUMBER | | | |
| | | | | H-1 J-0 K-0 | K-1 A-0 B-0 | B-1 C-0 D-0 | D-1 E-0 |
| 1 | LABEL - GROUND | PVC FILM | 451712-01 | 1 | 1 | 1 | 1 |
| 2 | CONTROL LABEL | (HE) (AUSTRALIA) (EXPORT) (OCEANIA) (GENERAL) (HSP) | 340941-01 | 1 | 1 | 1 | 1 |
| | CONTROL LABEL | (KOREA) | 463007-01 | | | 1 | 1 |
| 3 | LABEL - SWITCH | PVC FILM | 454374-01 | 1 | 1 | 1 | 1 |
| 4 | NAMEPLATE | | N/A | 1 | 1 | 1 | 1 |
| 5 | LEBEL - TERMINAL | PAPER | 452379-03 | 1 | 1 | 1 | 1 |
| 6 | LABEL - TERMINAL | PAPER | 452379-04 | 1 | 1 | 1 | 1 |
| 7 | CAUTION LABEL | PVC FILM | 452552-01 | 1 | 1 | 1 | 1 |
| 8 | CAUTION LABEL | (KOREA) | 463589-01 | | | 1 | 1 |
| 9 | CAUTION LABEL | (KOREA) | 463590-01 | | | 1 | 1 |
| | | | | | | | |
| | | | | | | | |
| | | | | | | | |
| | | | | | | | |
| | | | | | | | |
| | | | | | | | |
| | | | | | | | |
| | | | | | | | |
| | | | | | | | |
| | | | | | | | |
| | | | | | | | |
| | | | | | | | |
| | | | | | | | |
| | | | | | | | |
| | | | | | | | |
| | | | | | | | |
| | | | | | | | |
| | | | | | | | |
| | | | | | | | |
| | | | | | | | |
| | | | | | | | |
| | | | | | | | |
| | | | | | | | |
| | | | | | | | |
| | | | | | | | |
| | | | | | | | |
| | | | | | | | |
| | | | | | | | |
| | | | | | | | |
| | | | | | | | |
| | | | | | | | |
| | | | | | | | |
| | | | | | | | |
| | | | | | | | |
| | | | | | | | |
| | | | | | | | |
| | | | | | | | |
| | | | | | | | |
| | | | | | | | |
| | | | | | | | |
| | | | | | | | |
| | | | | | | | |
| | | | | | | | |
| | | | | | | | |
| | | | | | | | |
| | | | | | | | |
| | | | | | | | |
| | | | | | | | |
| | | | | | | | |

HE, GENERAL(50Hz), EXPORT(60Hz), AUSTRALIA, OCEANIA, HSP,KOREA

| MODEL : IM-45CLE-25, IM-45CLE | | TITLE : G. LABEL LOCATION | | | | | |
|--------------------------------------|--------------------------|--|-------------|--------------|-------------------|-----|------------|
| INDEX NO. | DESCRIPTION | MATERIAL OR MODEL NUMBER | PART NUMBER | REQ'D NUMBER | | | |
| | | | | E-1 | E-2 F-0 G-0 | G-1 | G-2 T-0 |
| 1 | LABEL - GROUND | PVC FILM | 451712-01 | 1 | 1 | 1 | 1 |
| 2 | CONTROL LABEL | (HE) (AUSTRALIA) (EXPORT) (OCEANIA) (GENERAL) (HSP) | 340941-01 | 1 | 1 | 1 | 1 |
| | CONTROL LABEL | (KOREA) | 463007-01 | 1 | 1 | 1 | 1 |
| 3 | LABEL - SWITCH | PVC FILM | 454374-01 | 1 | 1 | 1 | 1 |
| 4 | NAMEPLATE | | N/A | 1 | 1 | 1 | 1 |
| 5 | LEBEL - TERMINAL | PAPER | 452379-03 | 1 | 1 | 1 | 1 |
| 6 | LABEL - TERMINAL | PAPER | 452379-04 | 1 | 1 | 1 | 1 |
| 7 | CAUTION LABEL | PVC FILM | 452552-01 | 1 | 1 | 1 | 1 |
| 8 | CAUTION LABEL | (KOREA) | 463589-01 | 1 | 1 | 1 | 1 |
| 9 | CAUTION LABEL | (KOREA) | 463590-01 | 1 | 1 | 1 | 1 |
| 10 | LABEL - CONTROLLER BOARD | PVC FILM | 467627-01 | 1 | 1 | 1 | 1 |
| | | | | | | | |
| | | | | | | | |
| | | | | | | | |
| | | | | | | | |
| | | | | | | | |
| | | | | | | | |
| | | | | | | | |
| | | | | | | | |
| | | | | | | | |
| | | | | | | | |
| | | | | | | | |
| | | | | | | | |
| | | | | | | | |
| | | | | | | | |
| | | | | | | | |
| | | | | | | | |
| | | | | | | | |
| | | | | | | | |
| | | | | | | | |
| | | | | | | | |
| | | | | | | | |
| | | | | | | | |
| | | | | | | | |
| | | | | | | | |
| | | | | | | | |
| | | | | | | | |
| | | | | | | | |
| | | | | | | | |
| | | | | | | | |
| | | | | | | | |

HE, GENERAL(50Hz), EXPORT(60Hz), AUSTRALIA, OCEANIA, HSP,KOREA,CHINA

| MODEL : IM-45CLE-25, IM-45CLE | | | | TITLE : G. LABEL LOCATION | | | |
|-------------------------------|--------------------------|--|-------------|---------------------------|--|--|--|
| INDEX NO. | DESCRIPTION | MATERIAL OR MODEL NUMBER | PART NUMBER | REQ'D NUMBER | | | |
| | | | | T-1,U-0 V-0,L-0 | | | |
| 1 | LABEL - GROUND | PVC FILM | 451712-01 | 1 | | | |
| 2 | CONTROL LABEL | (HE) (AUSTRALIA) (EXPORT) (OCEANIA) (GENERAL) (HSP)(CHINA) | 340941-01 | 1 | | | |
| | CONTROL LABEL | (KOREA) | 463007-01 | 1 | | | |
| 3 | LABEL - SWITCH | PVC FILM | 454374-01 | 1 | | | |
| 4 | NAMEPLATE | | N/A | 1 | | | |
| 5 | LEBEL - TERMINAL | PAPER | 452379-03 | 1 | | | |
| 6 | LABEL - TERMINAL | PAPER | 452379-04 | 1 | | | |
| 7 | CAUTION LABEL | PVC FILM | 452552-01 | 1 | | | |
| 8 | CAUTION LABEL | (KOREA) | 463589-01 | 1 | | | |
| 9 | CAUTION LABEL | (KOREA) | 463590-01 | 1 | | | |
| 10 | LABEL - CONTROLLER BOARD | PVC FILM | 467627-01 | 1 | | | |
| 11 | LABEL - COMMERCIAL | (CHINA) | 475135L01 | 1 | | | |
| | | | | | | | |
| | | | | | | | |
| | | | | | | | |
| | | | | | | | |
| | | | | | | | |
| | | | | | | | |
| | | | | | | | |
| | | | | | | | |
| | | | | | | | |
| | | | | | | | |
| | | | | | | | |
| | | | | | | | |
| | | | | | | | |
| | | | | | | | |
| | | | | | | | |
| | | | | | | | |
| | | | | | | | |
| | | | | | | | |
| | | | | | | | |
| | | | | | | | |
| | | | | | | | |

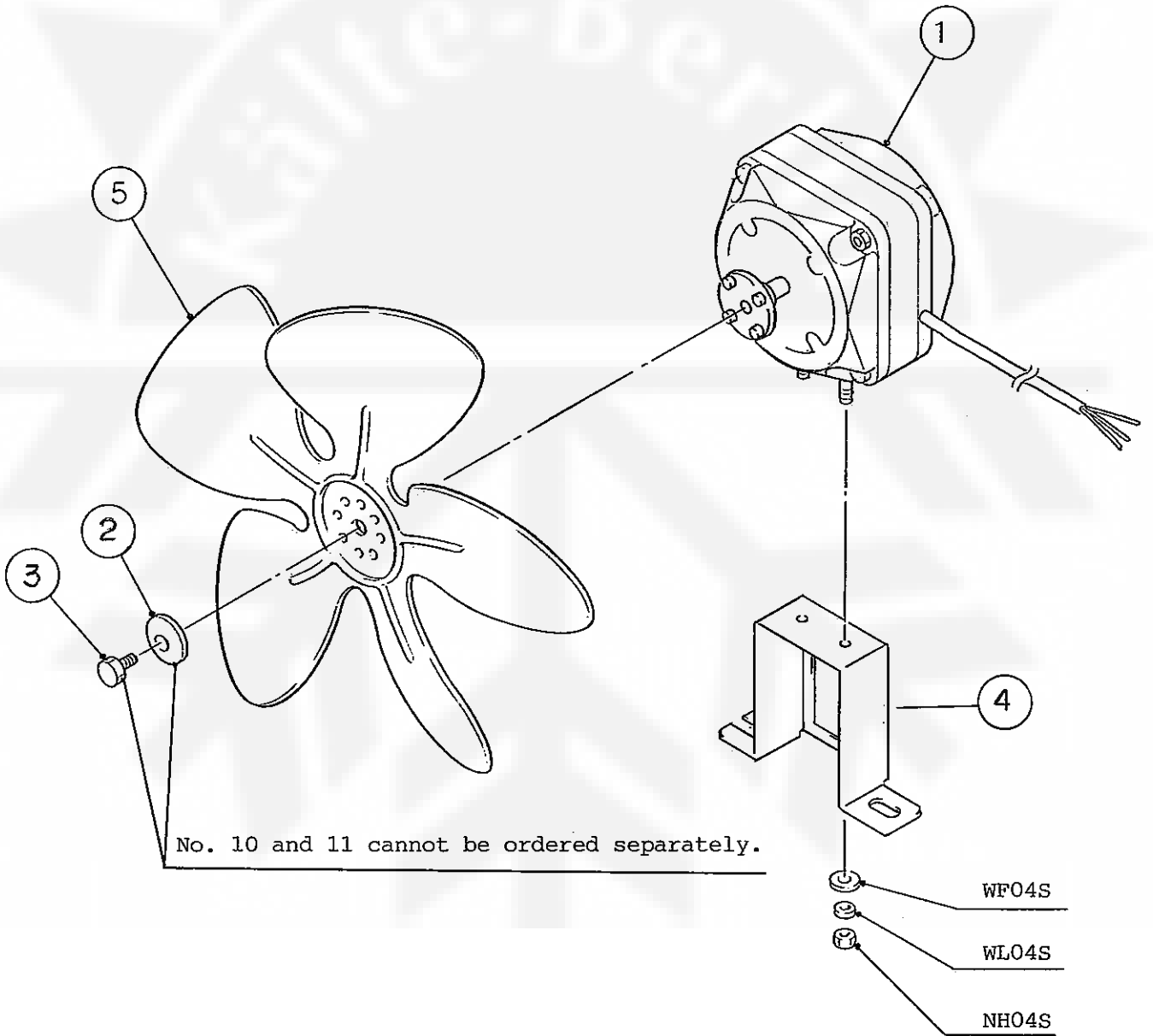

HE, GENERAL(50Hz), EXPORT(60Hz), AUSTRALIA, OCEANIA, HSP,KOREA

| MODEL : IM-45CLE-25, IM-45CLE | | | | TITLE : H. FAN MOTOR ASSY | | | |
|-------------------------------|---------------------|--------------------------|-------------|---------------------------|-------------------|-------------------|------------|
| INDEX NO. | DESCRIPTION | MATERIAL OR MODEL NUMBER | PART NUMBER | REQ'D NUMBER | | | |
| | | | | H-1 J-0 K-0 | K-1 A-0 B-0 | B-1 C-0 D-0 | D-1 E-0 |
| 1 | FAN MOTOR | M4Q045-CA11-51 | 451766-01 | 1 | 1 | 1 | 1 |
| 2 | WASHER - PAD | | 451766F02 | 1 | 1 | 1 | 1 |
| 3 | BOLT | | 451766F03 | 1 | 1 | 1 | 1 |
| 4 | BRACKET - FAN MOTOR | G.S | 4X5638-01 | 1 | 1 | 1 | 1 |
| 5 | FAN | 200 DIA | 451770-01 | 1 | 1 | 1 | 1 |
| | | | | | | | |
| | | | | | | | |
| | | | | | | | |
| | | | | | | | |
| | | | | | | | |
| | | | | | | | |
| | | | | | | | |
| | | | | | | | |
| | | | | | | | |
| | | | | | | | |
| | | | | | | | |
| | | | | | | | |
| | | | | | | | |
| | | | | | | | |
| | | | | | | | |
| | | | | | | | |
| | | | | | | | |
| | | | | | | | |
| | | | | | | | |
| | | | | | | | |
| | | | | | | | |
| | | | | | | | |
| | | | | | | | |
| | | | | | | | |
| | | | | | | | |
| | | | | | | | |
| | | | | | | | |

HE, GENERAL(50Hz), EXPORT(60Hz), AUSTRALIA, OCEANIA, HSP,KOREA

| MODEL : IM-45CLE-25, IM-45CLE | | | | TITLE : H. FAN MOTOR ASSY | | | |
|-------------------------------|---------------------|--------------------------|-------------|---------------------------|-------------------|-----|------------|
| INDEX NO. | DESCRIPTION | MATERIAL OR MODEL NUMBER | PART NUMBER | REQ'D NUMBER | | | |
| | | | | E-1 | E-2 F-0 G-0 | G-1 | G-2 T-0 |
| 1 | FAN MOTOR | M4Q045-CA11-51 | 451766-01 | 1 | 1 | 1 | 1 |
| 2 | WASHER - PAD | | 451766F02 | 1 | 1 | 1 | 1 |
| 3 | BOLT | | 451766F03 | 1 | 1 | 1 | 1 |
| 4 | BRACKET - FAN MOTOR | G.S | 4X5638-01 | 1 | 1 | 1 | 1 |
| 5 | FAN | 200 DIA | 451770-01 | 1 | 1 | 1 | 1 |
| | | | | | | | |
| | | | | | | | |
| | | | | | | | |
| | | | | | | | |
| | | | | | | | |
| | | | | | | | |
| | | | | | | | |
| | | | | | | | |
| | | | | | | | |
| | | | | | | | |
| | | | | | | | |
| | | | | | | | |
| | | | | | | | |
| | | | | | | | |
| | | | | | | | |
| | | | | | | | |
| | | | | | | | |
| | | | | | | | |
| | | | | | | | |
| | | | | | | | |
| | | | | | | | |
| | | | | | | | |
| | | | | | | | |
| | | | | | | | |

HE, GENERAL(50Hz), EXPORT(60Hz), AUSTRALIA, OCEANIA, HSP,KOREA,CHINA

| MODEL : IM-45CLE-25, IM-45CLE | | TITLE : H. FAN MOTOR ASSY | | | | | |
|--------------------------------------|---------------------|----------------------------------|-------------|--------------------|--|--|--|
| INDEX NO. | DESCRIPTION | MATERIAL OR MODEL NUMBER | PART NUMBER | REQ'D NUMBER | | | |
| | | | | T-1,U-0 V-0,L-0 | | | |
| 1 | FAN MOTOR | M4Q045-CA11-51 | 451766-01 | 1 | | | |
| 2 | WASHER - PAD | | 451766F02 | 1 | | | |
| 3 | BOLT | | 451766F03 | 1 | | | |
| 4 | BRACKET - FAN MOTOR | G.S | 4X5638-01 | 1 | | | |
| 5 | FAN | 200 DIA | 451770-01 | 1 | | | |
| | | | | | | | |
| | | | | | | | |
| | | | | | | | |
| | | | | | | | |
| | | | | | | | |
| | | | | | | | |
| | | | | | | | |
| | | | | | | | |
| | | | | | | | |
| | | | | | | | |
| | | | | | | | |
| | | | | | | | |
| | | | | | | | |
| | | | | | | | |
| | | | | | | | |
| | | | | | | | |
| | | | | | | | |
| | | | | | | | |
| | | | | | | | |
| | | | | | | | |
| | | | | | | | |
| | | | | | | | |
| | | | | | | | |
| | | | | | | | |
| | | | | | | | |
| | | | | | | | |
| | | | | | | | |
| | | | | | | | |
| | | | | | | | |
| | | | | | | | |
| | | | | | | | |

IM-45CLE-25
IM-45CLE

J. BIN CONTROL SWITCH ASSY

(D-0) (D-1) (E-0) (E-1) and later
(A-0) (B-0) (B-1) (C-0)
(H-1) (J-0) (K-0) (K-1)

(D-0) (D-1) (E-0) (E-1) and later
(A-0) (B-0) (B-1) (C-0)
(H-1) (J-0) (K-0) (K-1)

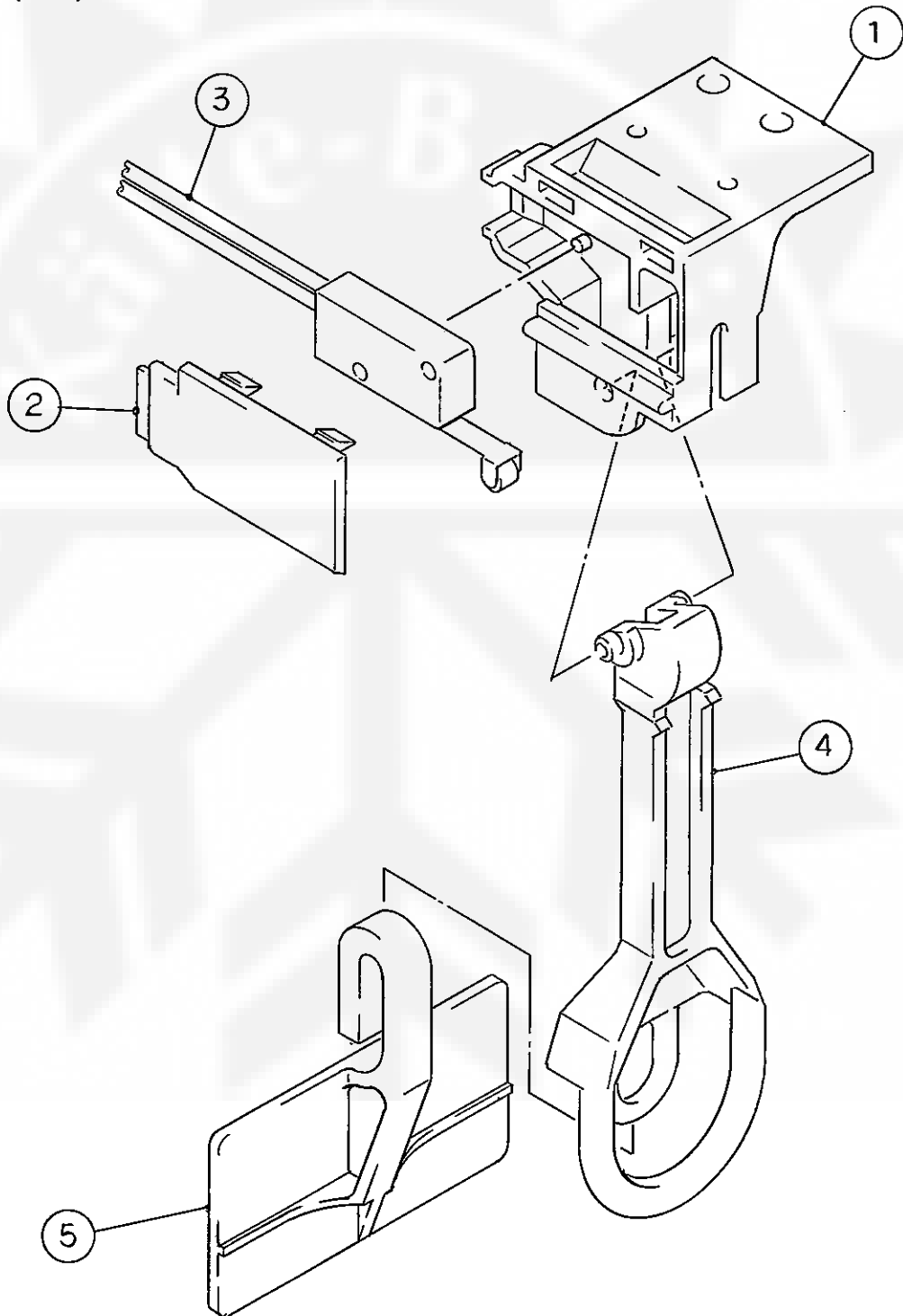

HE, GENERAL(50Hz), EXPORT(60Hz), AUSTRALIA, OCEANIA, HSP,KOREA

| MODEL : IM-45CLE-25, IM-45CLE | | TITLE : J. BIN CONTROL SWITCH ASSY | | | | | |
|-------------------------------|------------------|------------------------------------|-------------|-------------------|-------------------|-------------------|------------|
| INDEX NO. | DESCRIPTION | MATERIAL OR MODEL NUMBER | PART NUMBER | REQ'D NUMBER | | | |
| | | | | H-1 J-0 K-0 | K-1 A-0 B-0 | B-1 C-0 D-0 | D-1 E-0 |
| 1 | SWITCH BOX | PC | 2H2043-01 | 1 | 1 | 1 | 1 |
| 2 | SWITCH BOX COVER | PC | 4H8785-01 | 1 | 1 | 1 | 1 |
| 3 | MICROSWITCH | ABV1636618F2 | 456432-02 | 1 | 1 | 1 | 1 |
| 4 | SWITCH ACTUATOR | PC | 3H1369-01 | 1 | 1 | 1 | 1 |
| 5 | DETECTOR | ABS | 3H9308-01 | 1 | 1 | 1 | 1 |
| | | | | | | | |
| | | | | | | | |
| | | | | | | | |
| | | | | | | | |
| | | | | | | | |
| | | | | | | | |
| | | | | | | | |
| | | | | | | | |
| | | | | | | | |
| | | | | | | | |
| | | | | | | | |
| | | | | | | | |
| | | | | | | | |
| | | | | | | | |
| | | | | | | | |
| | | | | | | | |
| | | | | | | | |
| | | | | | | | |
| | | | | | | | |
| | | | | | | | |
| | | | | | | | |
| | | | | | | | |
| | | | | | | | |
| | | | | | | | |

HE, GENERAL(50Hz), EXPORT(60Hz), AUSTRALIA, OCEANIA, HSP,KOREA

| MODEL : IM-45CLE-25, IM-45CLE | | TITLE : J. BIN CONTROL SWITCH ASSY | | | | | |
|-------------------------------|------------------|------------------------------------|-------------|--------------|-------------------|-----|------------|
| INDEX NO. | DESCRIPTION | MATERIAL OR MODEL NUMBER | PART NUMBER | REQ'D NUMBER | | | |
| | | | | E-1 | E-2 F-0 G-0 | G-1 | G-2 T-0 |
| 1 | SWITCH BOX | PC | 2H2043-01 | 1 | 1 | 1 | 1 |
| 2 | SWITCH BOX COVER | PC | 4H8785-01 | 1 | 1 | 1 | 1 |
| 3 | MICROSWITCH | ABV1636618F2 | 456432-02 | 1 | 1 | 1 | 1 |
| 4 | SWITCH ACTUATOR | PC | 3H1369-01 | 1 | 1 | 1 | 1 |
| 5 | DETECTOR | ABS | 3H9308-01 | 1 | 1 | 1 | 1 |
| | | | | | | | |
| | | | | | | | |
| | | | | | | | |
| | | | | | | | |
| | | | | | | | |
| | | | | | | | |
| | | | | | | | |
| | | | | | | | |
| | | | | | | | |
| | | | | | | | |
| | | | | | | | |
| | | | | | | | |
| | | | | | | | |
| | | | | | | | |
| | | | | | | | |
| | | | | | | | |
| | | | | | | | |
| | | | | | | | |
| | | | | | | | |
| | | | | | | | |
| | | | | | | | |
| | | | | | | | |
| | | | | | | | |
| | | | | | | | |
| | | | | | | | |
| | | | | | | | |
| | | | | | | | |
| | | | | | | | |
| | | | | | | | |
| | | | | | | | |
| | | | | | | | |
| | | | | | | | |

HE, GENERAL(50Hz), EXPORT(60Hz), AUSTRALIA, OCEANIA, HSP,KOREA,CHINA

| MODEL : IM-45CLE-25, IM-45CLE | | | | TITLE : J. BIN CONTROL SWITCH ASSY | | | |
|-------------------------------|------------------|--------------------------|-------------|------------------------------------|--|--|--|
| INDEX NO. | DESCRIPTION | MATERIAL OR MODEL NUMBER | PART NUMBER | REQ'D NUMBER | | | |
| | | | | T-1,U-0 V-0,L-0 | | | |
| 1 | SWITCH BOX | PC | 2H2043-01 | 1 | | | |
| 2 | SWITCH BOX COVER | PC | 4H8785-01 | 1 | | | |
| 3 | MICROSWITCH | ABV1636618F2 | 456432-02 | 1 | | | |
| 4 | SWITCH ACTUATOR | PC | 3H1369-01 | 1 | | | |
| 5 | DETECTOR | ABS | 3H9308-01 | 1 | | | |
| | | | | | | | |
| | | | | | | | |
| | | | | | | | |
| | | | | | | | |
| | | | | | | | |
| | | | | | | | |
| | | | | | | | |
| | | | | | | | |
| | | | | | | | |
| | | | | | | | |
| | | | | | | | |
| | | | | | | | |
| | | | | | | | |
| | | | | | | | |
| | | | | | | | |
| | | | | | | | |
| | | | | | | | |
| | | | | | | | |
| | | | | | | | |
| | | | | | | | |
| | | | | | | | |
| | | | | | | | |
| | | | | | | | |
| | | | | | | | |
| | | | | | | | |
| | | | | | | | |
| | | | | | | | |
| | | | | | | | |
| | | | | | | | |
| | | | | | | | |
| | | | | | | | |

IM-45CLE-25
IM-45CLE

K. WATER PAN ASSY

(D-0) (D-1) (E-0) (E-1) and later
(A-0) (B-0) (B-1) (C-0)
(H-1) (J-0) (K-0) (K-1)

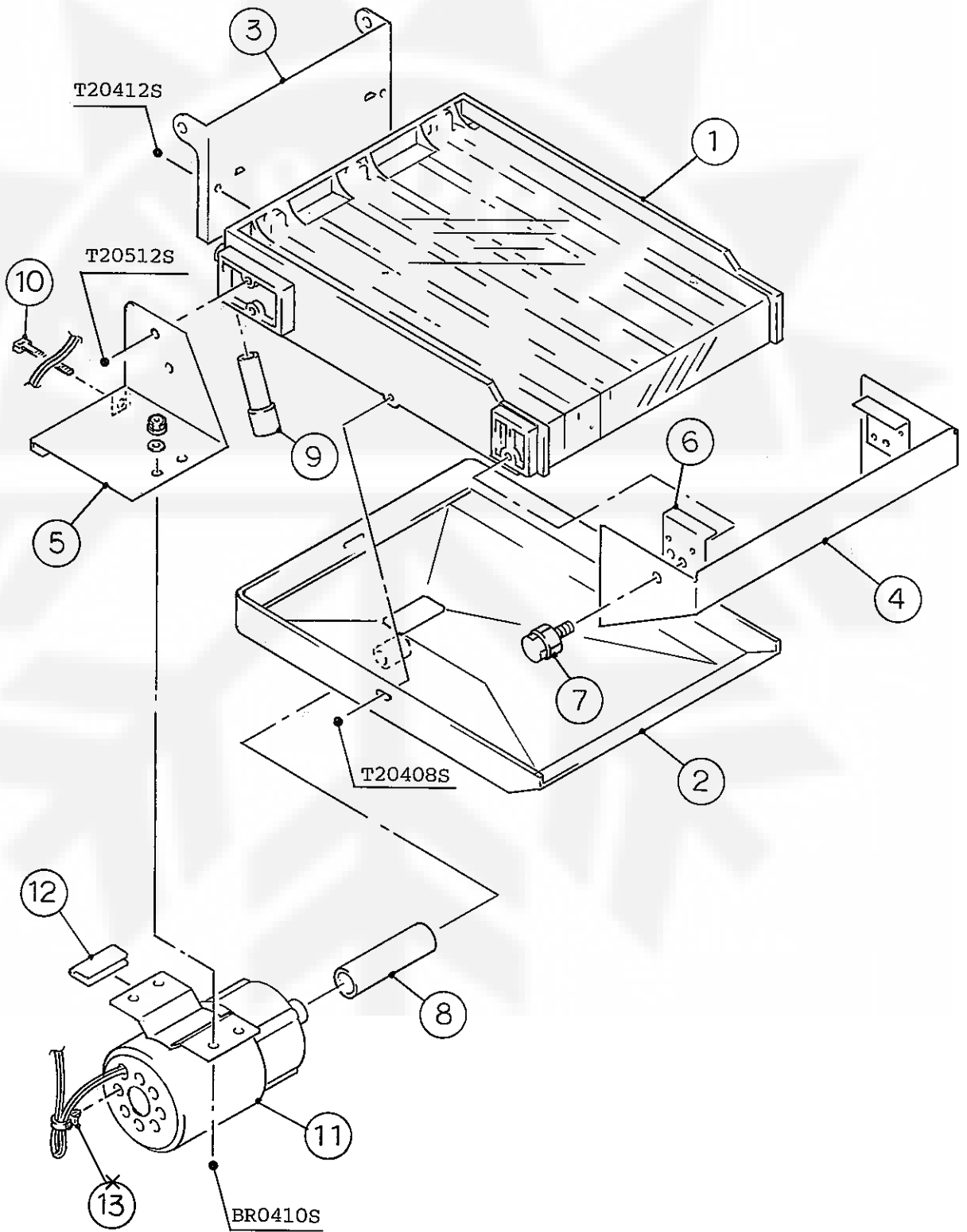

HE, GENERAL(50Hz), EXPORT(60Hz), AUSTRALIA, OCEANIA, HSP, KOREA

| MODEL : IM-45CLE-25, IM-45CLE | | | | TITLE : K. WATER PAN ASSY | | | |
|-------------------------------|----------------------|--------------------------|-------------|---------------------------|-------------------|-------------------|------------|
| INDEX NO. | DESCRIPTION | MATERIAL OR MODEL NUMBER | PART NUMBER | REQ'D NUMBER | | | |
| | | | | H-1 J-0 K-0 | K-1 A-0 B-0 | B-1 C-0 D-0 | D-1 E-0 |
| 1 | WATER PLATE | (IM-45CLE-25) | 2H0402G03 | 1 | 1 | 1 | 1 |
| | WATER PLATE | (IM-45CLE) | 2H0402G02 | 1 | 1 | 1 | 1 |
| 2 | WATER TANK | ABS | 4X4159-02 | 1 | 1 | 1 | 1 |
| 3 | BRACKET - WATER PAN | S.S | 4H2643-01 | 1 | 1 | 1 | 1 |
| 4 | DRAIN GUIDE | ABS | 3H5521-01 | 1 | 1 | 1 | 1 |
| 5 | BRACKET - PUMP MOTOR | S.S | 4H2642-04 | 1 | 1 | 1 | 1 |
| 6 | PLATE - LUBRICATION | S.S | 4H0448-01 | 2 | 2 | 2 | 2 |
| 7 | SCREW - SPRING HOOK | AC | 4H2582G01 | 2 | 2 | 2 | 2 |
| 8 | SUCTION TUBING | SI | 4H1922-02 | 1 | 1 | 1 | 1 |
| 9 | DISCHARGE TUBING | SI | 4H1982-01 | 1 | 1 | 1 | 1 |
| 10 | TIE | CV-100 | 7920-0002 | 1 | 1 | 1 | 1 |
| 11 | PUMP MOTOR | LMP-10SP | 449587-01 | 1 | — | | |
| | | LMP-20CP | 456381-01 | | 1 | 1 | 1 |
| 12 | "U" PACKING | RUBBER | 4H2982-01 | 1 | 1 | 1 | 1 |
| 13 | CLAMP | 1C54 | 428644-04 | 1 | x | | |
| | | | | | | | |
| | | | | | | | |
| | | | | | | | |
| | | | | | | | |
| | | | | | | | |
| | | | | | | | |
| | | | | | | | |
| | | | | | | | |
| | | | | | | | |
| | | | | | | | |
| | | | | | | | |
| | | | | | | | |
| | | | | | | | |
| | | | | | | | |
| | | | | | | | |
| | | | | | | | |
| | | | | | | | |

HE, GENERAL(50Hz), EXPORT(60Hz), AUSTRALIA, OCEANIA, HSP, KOREA

| MODEL : IM-45CLE-25, IM-45CLE | | | | TITLE : K. WATER PAN ASSY | | | |
|-------------------------------|----------------------|--------------------------|-------------|---------------------------|-------------------|-----|------------|
| INDEX NO. | DESCRIPTION | MATERIAL OR MODEL NUMBER | PART NUMBER | REQ'D NUMBER | | | |
| | | | | E-1 | E-2 F-0 G-0 | G-1 | G-2 T-0 |
| 1 | WATER PLATE | (IM-45CLE-25) | 2H0402G03 | 1 | 1 | 1 | 1 |
| | WATER PLATE | (IM-45CLE) | 2H0402G02 | 1 | 1 | 1 | 1 |
| 2 | WATER TANK | ABS | 4X4159-02 | 1 | 1 | 1 | 1 |
| 3 | BRACKET - WATER PAN | S.S | 4H2643-01 | 1 | 1 | 1 | 1 |
| 4 | DRAIN GUIDE | ABS | 3H5521-01 | 1 | 1 | 1 | 1 |
| 5 | BRACKET - PUMP MOTOR | S.S | 4H2642-04 | 1 | 1 | 1 | 1 |
| 6 | PLATE - LUBRICATION | S.S | 4H0448-01 | 2 | 2 | 2 | 2 |
| 7 | SCREW - SPRING HOOK | AC | 4H2582G01 | 2 | 2 | 2 | 2 |
| 8 | SUCTION TUBING | SI | 4H1922-02 | 1 | 1 | 1 | 1 |
| 9 | DISCHARGE TUBING | SI | 4H1982-01 | 1 | 1 | 1 | 1 |
| 10 | TIE | CV-100 | 7920-0002 | 1 | 1 | 1 | 1 |
| 11 | PUMP MOTOR | - | - | | | | |
| | | LMP-20CP | 456381-01 | 1 | 1 | 1 | 1 |
| 12 | "U" PACKING | RUBBER | 4H2982-01 | 1 | 1 | 1 | 1 |
| 13 | CLAMP | - | - | | | | |
| | | | | | | | |
| | | | | | | | |
| | | | | | | | |
| | | | | | | | |
| | | | | | | | |
| | | | | | | | |
| | | | | | | | |
| | | | | | | | |
| | | | | | | | |
| | | | | | | | |
| | | | | | | | |
| | | | | | | | |
| | | | | | | | |
| | | | | | | | |
| | | | | | | | |

HE, GENERAL(50Hz), EXPORT(60Hz), AUSTRALIA, OCEANIA, HSP, KOREA, CHINA

| MODEL : IM-45CLE-25, IM-45CLE | | | | TITLE : K. WATER PAN ASSY | | | |
|-------------------------------|----------------------|--------------------------|-------------|---------------------------|--|--|--|
| INDEX NO. | DESCRIPTION | MATERIAL OR MODEL NUMBER | PART NUMBER | REQ'D NUMBER | | | |
| | | | | T-1,U-0 V-0,L-0 | | | |
| 1 | WATER PLATE | (IM-45CLE-25) | 2H0402G03 | 1 | | | |
| | WATER PLATE | (IM-45CLE) | 2H0402G02 | 1 | | | |
| 2 | WATER TANK | ABS | 4X4159-02 | 1 | | | |
| 3 | BRACKET - WATER PAN | S.S | 4H2643-01 | 1 | | | |
| 4 | DRAIN GUIDE | ABS | 3H5521-01 | 1 | | | |
| 5 | BRACKET - PUMP MOTOR | S.S | 4H2642-04 | 1 | | | |
| 6 | PLATE - LUBRICATION | S.S | 4H0448-01 | 2 | | | |
| 7 | SCREW - SPRING HOOK | AC | 4H2582G01 | 2 | | | |
| 8 | SUCTION TUBING | SI | 4H1922-02 | 1 | | | |
| 9 | DISCHARGE TUBING | SI | 4H1982-01 | 1 | | | |
| 10 | TIE | CV-100 | 7920-0002 | 1 | | | |
| 11 | PUMP MOTOR | LMP-20CP | 456381-01 | 1 | | | |
| 12 | "U" PACKING | RUBBER | 4H2982-01 | 1 | | | |
| 13 | CLAMP | - | - | | | | |
| | | | | | | | |
| | | | | | | | |
| | | | | | | | |
| | | | | | | | |
| | | | | | | | |
| | | | | | | | |
| | | | | | | | |
| | | | | | | | |
| | | | | | | | |
| | | | | | | | |
| | | | | | | | |
| | | | | | | | |
| | | | | | | | |
| | | | | | | | |

IM-45CLE-25
IM-45CLE

L. ACCESSORIES

(D-0) (D-1) (E-0) (E-1) and later
(A-0) (B-0) (B-1) (C-0)
(H-1) (J-0) (K-0) (K-1)

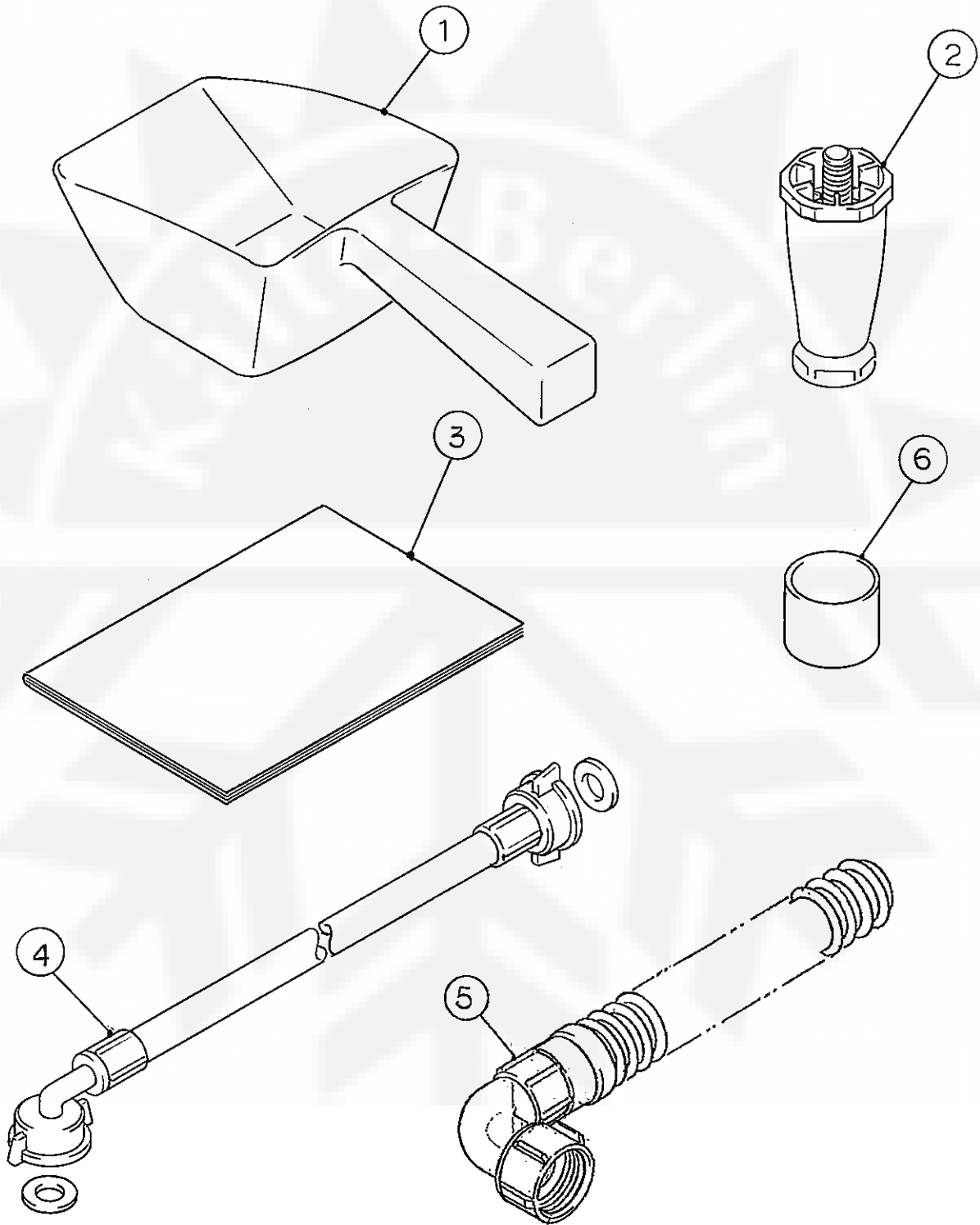

HE, GENERAL(50Hz), EXPORT(60Hz), AUSTRALIA, OCEANIA, HSP,KOREA

| MODEL : IM-45CLE-25, IM-45CLE TITLE : L. ACCESSORIES | | | | REQ'D NUMBER | | | |
|--|--------------------|--------------------------|-------------|--------------|-----|-----|-----|
| INDEX NO. | DESCRIPTION | MATERIAL OR MODEL NUMBER | PART NUMBER | H-1 | K-1 | B-1 | D-1 |
| | | | | J-0 | A-0 | C-0 | E-0 |
| | | | | K-0 | B-0 | D-0 | E-0 |
| 1 | SCOOP | PE | 2H0361-01 | 1 | 1 | 1 | 1 |
| 2 | LEG | | 462576-02 | 4 | 4 | 4 | 4 |
| 3 | INSTRUCTION MANUAL | PAPER | 91E1AX20A | 1 | - | | |
| | | PAPER | 91E1AX20B | | 1 | 1 | 1 |
| | | PAPER | 91E1AX20F | | | | |
| 4 | INLET HOSE | - | 450722-01 | 1 | 1 | 1 | 1 |
| 5 | OUTLET HOSE | - | 452365-01 | 1 | 1 | 1 | 1 |
| 6 | CAP | PE | 417323-01 | 1 | 1 | 1 | 1 |
| | | | | | | | |
| | | | | | | | |
| | | | | | | | |
| | | | | | | | |
| | | | | | | | |
| | | | | | | | |
| | | | | | | | |
| | | | | | | | |
| | | | | | | | |
| | | | | | | | |
| | | | | | | | |
| | | | | | | | |
| | | | | | | | |
| | | | | | | | |
| | | | | | | | |
| | | | | | | | |
| | | | | | | | |
| | | | | | | | |
| | | | | | | | |
| | | | | | | | |
| | | | | | | | |
| | | | | | | | |
| | | | | | | | |
| | | | | | | | |
| | | | | | | | |
| | | | | | | | |
| | | | | | | | |
| | | | | | | | |
| | | | | | | | |
| | | | | | | | |
| | | | | | | | |
| | | | | | | | |
| | | | | | | | |
| | | | | | | | |
| | | | | | | | |
| | | | | | | | |
| | | | | | | | |
| | | | | | | | |

HE, GENERAL(50Hz), EXPORT(60Hz), AUSTRALIA, OCEANIA, HSP,KOREA

| MODEL : IM-45CLE-25, IM-45CLE TITLE : L. ACCESSORIES | | | | | | | |
|--|--------------------|--------------------------|-------------|--------------|-------------------|-----|------------|
| INDEX NO. | DESCRIPTION | MATERIAL OR MODEL NUMBER | PART NUMBER | REQ'D NUMBER | | | |
| | | | | E-1 | E-2 F-0 G-0 | G-1 | G-2 T-0 |
| 1 | SCOOP | PE | 2H0361-01 | 1 | 1 | 1 | 1 |
| 2 | LEG | | 462576-02 | 4 | 4 | 4 | 4 |
| 3 | INSTRUCTION MANUAL | - | - | | | | |
| | | PAPER | 91E1AX20B | — | | | |
| | | PAPER | 91E1AX20F | 1 | 1 | 1 | 1 |
| 4 | INLET HOSE | - | 450722-01 | 1 | 1 | 1 | 1 |
| 5 | OUTLET HOSE | - | 452365-01 | 1 | 1 | 1 | 1 |
| 6 | CAP | PE | 417323-01 | 1 | 1 | 1 | 1 |
| | | | | | | | |
| | | | | | | | |
| | | | | | | | |
| | | | | | | | |
| | | | | | | | |
| | | | | | | | |
| | | | | | | | |
| | | | | | | | |
| | | | | | | | |
| | | | | | | | |
| | | | | | | | |
| | | | | | | | |
| | | | | | | | |
| | | | | | | | |
| | | | | | | | |
| | | | | | | | |
| | | | | | | | |
| | | | | | | | |
| | | | | | | | |
| | | | | | | | |
| | | | | | | | |
| | | | | | | | |
| | | | | | | | |
| | | | | | | | |
| | | | | | | | |
| | | | | | | | |
| | | | | | | | |
| | | | | | | | |
| | | | | | | | |
| | | | | | | | |
| | | | | | | | |
| | | | | | | | |
| | | | | | | | |
| | | | | | | | |
| | | | | | | | |
| | | | | | | | |
| | | | | | | | |
| | | | | | | | |
| | | | | | | | |

HE, GENERAL(50Hz), EXPORT(60Hz), AUSTRALIA, OCEANIA, HSP,KOREA,CHINA

| MODEL : IM-45CLE-25, IM-45CLE | | | | | TITLE : L. ACCESSORIES | | | |
|-------------------------------|--------------------|--------------------------|-------------|--------------------|------------------------|--|--|--|
| INDEX NO. | DESCRIPTION | MATERIAL OR MODEL NUMBER | PART NUMBER | REQ'D NUMBER | | | | |
| | | | | T-1,U-0 V-0,L-0 | | | | |
| 1 | SCOOP | PE | 2H0361-01 | 1 | | | | |
| 2 | LEG | | 462576-02 | 4 | | | | |
| 3 | INSTRUCTION MANUAL | PAPER | 91E1AX20F | 1 | | | | |
| | | (CHINA) | L1E1AX301 | 1 | | | | |
| 4 | INLET HOSE | - | 450722-01 | 1 | | | | |
| 5 | OUTLET HOSE | - | 452365-01 | 1 | | | | |
| 6 | CAP | PE | 417323-01 | 1 | | | | |
| | | | | | | | | |
| | | | | | | | | |
| | | | | | | | | |
| | | | | | | | | |
| | | | | | | | | |
| | | | | | | | | |
| | | | | | | | | |
| | | | | | | | | |
| | | | | | | | | |
| | | | | | | | | |
| | | | | | | | | |
| | | | | | | | | |
| | | | | | | | | |
| | | | | | | | | |
| | | | | | | | | |
| | | | | | | | | |
| | | | | | | | | |
| | | | | | | | | |
| | | | | | | | | |
| | | | | | | | | |
| | | | | | | | | |
| | | | | | | | | |
| | | | | | | | | |
| | | | | | | | | |
| | | | | | | | | |
| | | | | | | | | |
| | | | | | | | | |